

INSTALLATION DETAIL

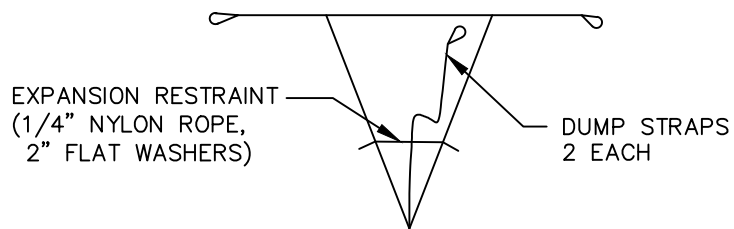

BAG DETAIL

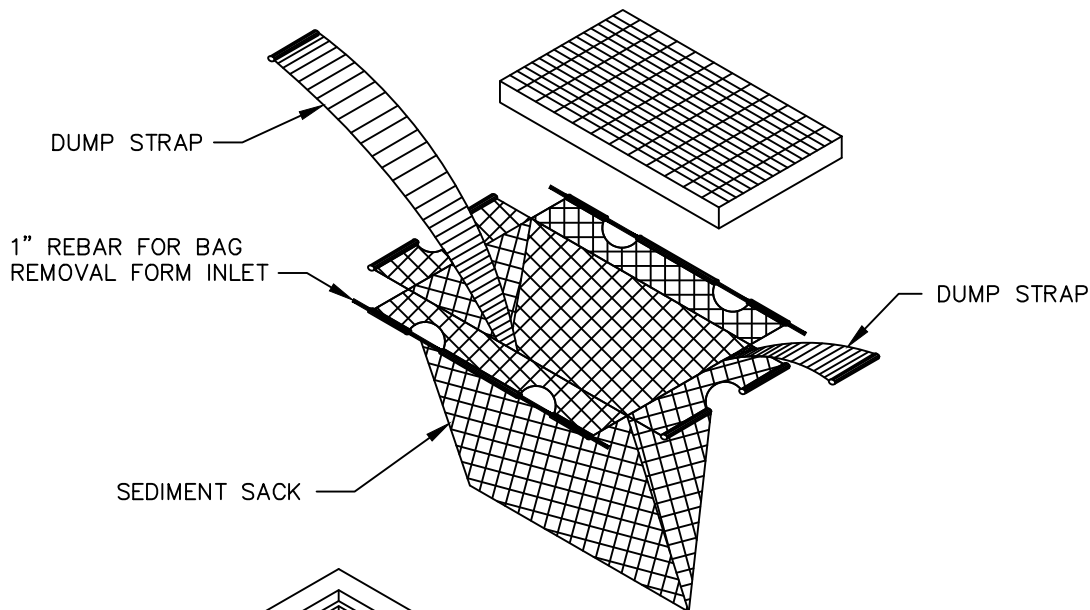
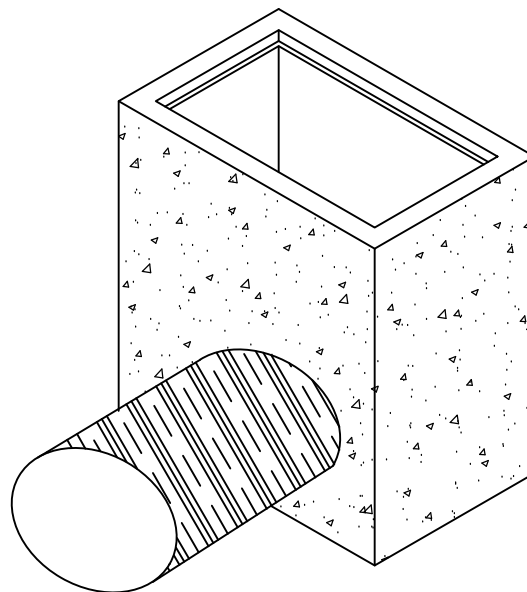

MAINTENANCE NOTES:

1. INSPECT BAG AFTER EACH SIGNIFICANT RAINFALL OF 1 INCHES OR GREATER, OVER A 24-HOUR PERIOD.
2. FOLLOW ROAD SAFETY WHILE PERFORMING MAINTENANCE.
3. REPLACE BAG WHEN THEY BECOME CONTAMINATED WITH SEDIMENT AND CONSTRUCTION DEBRIS.
4. WHEN MAINTAINING AND REMOVING INLET PROTECTION DEVICES, EXERCISE CARE TO MINIMIZE SEDIMENT FALLING INTO THE INLET. IMMEDIATELY REMOVE ALL MATERIAL THAT HAS FALLEN INTO INLETS. DEPOSIT SEDIMENT REMOVED FROM THE DEVICE IN A SUITABLE AREA AND STABILIZE.



**STANDARD SILT BAG - INLET SEDIMENT CONTROL DEVICE**

EFFECTIVE: 10/15/2025