



Instruments That Advance The Art

Pixie Link

Multi-Channel Desktop Digital Pulse Processor

FEATURES

- Compact standalone detector readout electronics
- POSIX SMP real-time OS
- On-board MCA spectra
- Waveform capture and Pulse Shape Analysis
- Web interface
- 10 Gbps Ethernet output for list-mode data
- Sub-nanosecond Timing Resolution
- Desktop, rack mount, OEM



OVERVIEW

The Pixie Link is a multi-channel digital pulse processor designed for high-precision experiments using HPGe, scintillator, or silicon detectors. Besides nuclear spectroscopy, the Pixie-Net XL can be used for neutron/gamma discrimination, time-of-flight measurements, and coincidence/anti-coincidence measurements.

Built on XIA's proven digital pulse processing, the Pixie Link combines an embedded POSIX SMB real-time OS with a high-speed FPGA. This combination provides you not only with energy and time, but also with digitized waveforms, CFD, and pulse-shape analysis. These data make the system capable of instrumenting nearly any experiment that requires robust data acquisition.

The Pixie Link delivers a complete, network-integrated solution for demanding applications. It works with commercial off-the-shelf networking gear making integrating with existing networks much easier. The desktop form-factor makes the system easy to install near the detectors. Co-location shortens your cable lengths and can reduce your overall experimental costs.

APPLICATIONS

- Scintillator, HPGe, Si detectors
- Real-time Pulse-Shape Discrimination
- Clover detectors
- Distributed Data Acquisition
- Homeland Security
- OEM systems
- Remote monitoring



XIA LLC

xia.com

sales@xia.com Tel: +1-510-401-5760

2744 East 11th St Suite H2, Oakland, CA 94601 USA

ARCHITECTURE

Two ADC Daughtercard Slots, Each Capable of

- 8 channels, 14bit, 250 MHz, variable offset, fixed gain, 0.1" header input connectors

Two Pulse Processing FPGAs With

- High speed LVDS I/O to daughtercard
- Dedicated SFP cage for 1 or 10 Gbps Ethernet (copper or optical)
- 4 Gbit DDR3 SDRAM
- Direct path of DAQ data from FPGA to remote storage
- List mode data output rates up to 500,000 events/s, 70 MB/s (1G) or 350 MB/s (10G)

Zynq “System on Chip” Platform acting as integrated DAQ PC

- Dual-core ARM® Cortex™-A9 with Xilinx 7-series FPGA section
- Gigabit Ethernet, 1GB RAM, USB2.0, 16 GB SD card storage
- RTEMS
- Embedded web page for monitoring and configuration

Network Time Synchronization

- 1PPS out, clock in, clock out

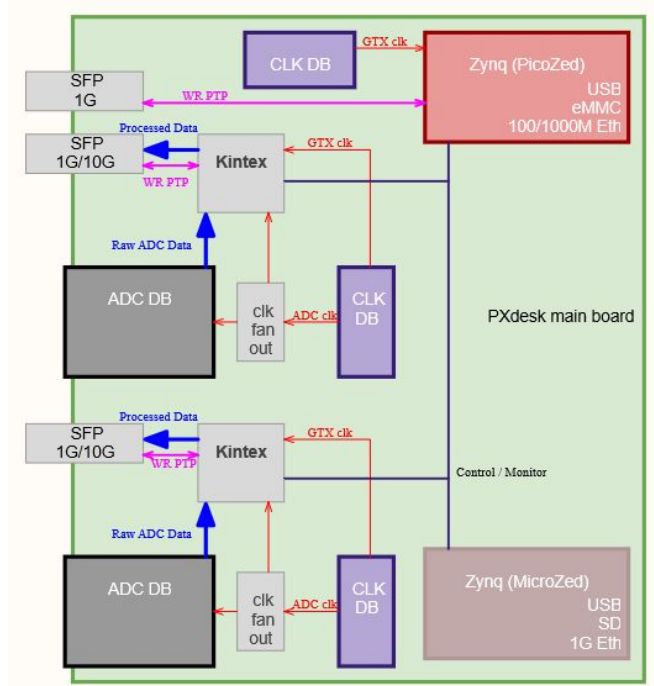

High Speed Data Flow: ADC ► FPGA ► Ethernet SFP

Timing Performance

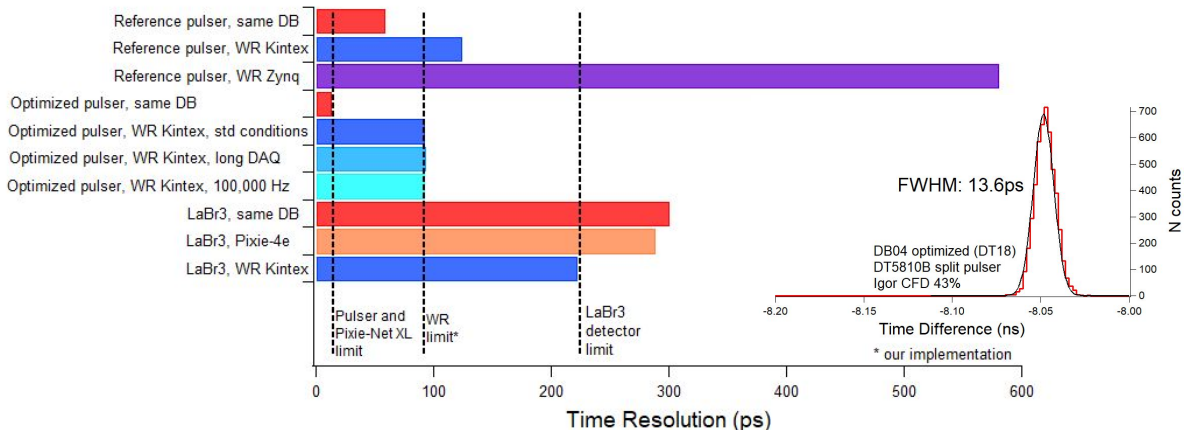

Summary of time resolution for split pulser and scintillator pair, same daughtercard or White Rabbit synchronization

XIA LLC

www.xia.com

sales@xia.com Tel: +1-510-401-5760

2744 East 11th St, Oakland, CA 94601 USA