

**SOURCE TEST REPORT FOR
2026 1ST QUARTER LEACHATE AND CONDENSATE
VAPOR SAMPLING AT THE
CHIQUITA CANYON LANDFILL
FACILITY ID: 119219**

Prepared For:

SCS Engineers – Chiquita Canyon Landfill
3900 Kilroy Airport Way, Suite 100
Long Beach, California 90806

For Submittal To:

South Coast Air Quality Management District
21865 Copley Drive
Diamond Bar, California 91765-4178

Prepared By:

Montrose Air Quality Services, LLC
1631 E. St. Andrew Pl.
Santa Ana, California 92705
(714) 279-6777

Pete San Juan

Test Date: **March 30, 2026**
Production Date: **April 28, 2026**
Document Number: **W002AS-066231-RT-8345**



CONFIDENTIALITY STATEMENT

Except as otherwise required by law or regulation, this information contained in this communication is intended exclusively for the individual or entity to which it is addressed. This communication may contain information that is proprietary, privileged or confidential or otherwise legally exempt from disclosure. If you are not the named addressee, you are not authorized to read, print, retain, copy, or disseminate this message or any part of it.

REVIEW AND CERTIFICATION

All work, calculations, and other activities and tasks performed and presented in this document were carried out by me or under my direction and supervision. I hereby certify that, to the best of my knowledge, Montrose operated in conformance with the requirements of the Montrose Quality Management System and ASTM D7036-04 during this test project.

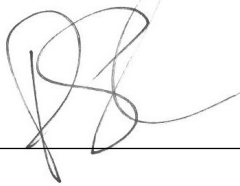
Signature:  _____ Date: 4/28/2026

Name: Pete SanJuan Title: Client Project Manager

I have reviewed, technically and editorially, details, calculations, results, conclusions, and other appropriate written materials contained herein. I hereby certify that, to the best of my knowledge, the presented material is authentic, accurate, and conforms to the requirements of the Montrose Quality Management System and ASTM D7036-04.

Signature:  _____ Date: 4/28/2026

Name: Surya Adhikari Title: Senior Reporting QC Specialist

TABLE OF CONTENTS

<u>SECTION</u>	<u>PAGE</u>
1.0 INTRODUCTION	5
2.0 FACILITY AND SOURCE INFORMATION.....	6
2.1 PROCESS EQUIPMENT INFORMATION	6
3.0 TEST INFORMATION AND METHODOLOGY	7
3.1 SCAQMD METHOD 1.1 – SAMPLING AND VELOCITY TRAVERSES FOR STATIONARY SOURCES	7
3.2 SCAQMD METHOD 2.1 – VELOCITY AND VOLUMETRIC FLOW RATE	8
3.3 SCAQMD METHOD 3.1 – GAS ANALYSIS FOR DRY MOLECULAR WEIGHT AND EXCESS AIR.....	8
3.4 SCAQMD METHOD 4.1 – DETERMINATION OF MOISTURE CONTENT IN STACK GASES	8
3.5 SCAQMD METHOD 307-91 – HYDROGEN SULFIDE AND REDUCED SULFUR COMPOUNDS.....	8
3.6 EPA METHOD TO-15 – VOLATILES AND HYDROCARBON COLLECTED IN SUMMA CANISTER	8
4.0 RESULTS.....	9

LIST OF APPENDICES

A TEST DATA.....	11
A.1 Sample Location Data	12
A.2 Velocity, Moisture and Flow Rate Data	20
A.3 Organics and Sulfur Field and Laboratory Data	36
A.4 Quality Assurance Data	66
B GENERAL EMISSIONS CALCULATIONS.....	76
C QUALITY ASSURANCE	79
C.1 Quality Assurance Program Summary.....	80
C.2 SCAQMD and STAC Certifications	86
C.3 Individual QI Certifications	89
C.4 Statement of No Conflict of Interest	93
D FACILITY PERMIT	95

LIST OF TABLES

3-1 TEST PROCEDURES	7
4-1 H ₂ S AND TOTAL REDUCED SULFUR RESULTS	9
4-2 TRACE ORGANICS SPECIES RESULTS.....	10

1.0 INTRODUCTION

Montrose Air Quality Services, LLC (MAQS) was contacted by SCS Engineers (SCS) to conduct quarterly sampling at various locations on the vapor ventilation system located at the Chiquita Canyon Landfill (Chiquita), in Castaic, California. Testing was conducted to comply with Condition 72 of the Modified Stipulated Order for Abatement (SOFA) issued to Chiquita by the South Coast Air Quality Management District (SCAQMD). The tests were conducted according to the test protocol (MAQS Document Number W002AS-056454-PP-1074) and source test protocol evaluation (S/T ID: P24228). The Montrose test team consisted of Pete San Juan, Allen Dusky, and Ray Madrigal. Pete San Juan was the on-site qualified individual for MAQS. MAQS qualifies as an independent testing laboratory under SCAQMD Rule 304 (no conflict of interest) and is certified by the SCAQMD to conduct testing for criteria pollutants according to District Methods.

Equipment and facility information is provided in Section 2.0. Source test information is detailed in Section 3.0. Test results are provided in Section 4.0. Supplemental information is contained in the Appendices.

2.0 FACILITY AND SOURCE INFORMATION

The facility address is:

Physical Address: Chiquita Canyon Landfill
29201 Henry Mayo Drive
Castaic, California 91384

Sampling of leachate and condensate vapors was conducted from the following locations:

- The tank vents or manifolds which are representative of a set of tanks;
- The header/manifold from each leachate tank farm or manifold including inlet to the Parnel Flare, inlet to the Zeeco Flare, inlet to the Hero FLare, Tank Farm Canyon D, Tank Farm 13, Flare Station Pre-H₂S treatment, and Flare Station Post-H₂S treatment. Testing was performed upstream of the piping connection to the LFG Collection and Conveyance System where landfill gas may affect results.

2.1 PROCESS EQUIPMENT INFORMATION

Vapors created from the volatilization of chemicals in the head space in the leachate tanks at tank farms, Canyon D, and #13 are transferred under vacuum through the wellhead and into the landfill gas collection system then to the flare station for combustion. The pressure and temperature of the vapors in the piping varies based on ambient temperatures during normal operation. The facility operates 24 hours per day. Photographs of the locations sampled are located in Appendix A.1.

3.0 TEST INFORMATION AND METHODOLOGY

The pollutants measured and test methodology are summarized in Table 3-1. Volume flow rate measurements were performed before the sample collection.

The field sampling procedures utilized during the test program are described below. The published reference methods provide greater detailed descriptions than in this section. The purpose of this section is to provide an overview of the sampling methods and any variations. The sampling procedures are based on SCAQMD and EPA Reference Methods.

**TABLE 3-1
 TEST PROCEDURES
 TEST PROGRAM OVERVIEW
 CHIQUITA CANYON LANDFILL
 LEACHATE AND CONDENSATE VAPOR SAMPLING**

Parameter	Sample Medium	Analytical Technique	Reference Method	Number of Replicates
Flow Rate/Temperature	Pitot Tube / TC	Differential Pressure	SCAQMD 2.1	1 for each location
Moisture	Wet Bulb/Dry Bulb	Psychrometric Chart	SCAQMD 4.1	1 for each location
H ₂ S and TRS	Summa Can	GC/SCD	SCAQMD 307-91	1 for each location
TO-15 (Rule 1150.1)	Summa Can	GC/MS	EPA TO-15	1 for each location

3.1 SCAQMD METHOD 1.1 – SAMPLING AND VELOCITY TRAVERSES FOR STATIONARY SOURCES

A preliminary source test site assessment was performed prior to the source test in order to determine applicable sample point traverse locations. The stack diameter, and the distance from sample ports to disturbances (bends, flanges, etc.), both upstream and downstream, were measured. This information is utilized to determine the minimum number of sampling points per traverse, and the distance from the inner stack wall to each sample point location. All sample locations were located according to the minimum requirements of SCAQMD Method 1.1. Additionally, this method considers cyclonic flow patterns and in-situ stratified pollutant concentrations. Cyclonic flow tests were performed at locations where flow was measurable.

3.2 SCAQMD METHOD 2.1 – VELOCITY AND VOLUMETRIC FLOW RATE

The velocity of the gas stream was determined by using an "S" type or standard pitot tube, a low flow electronic manometer, and type "K" thermocouple with a digital temperature measuring device. The calibrated pitot tube is connected to the calibrated electronic Air Data Multimeter (ADM) manometer and leak checked. A temperature and delta P is obtained at each traverse point, and a duct static pressure is measured and recorded. The dry volumetric flow rate is determined from the gas velocity data, stack pressure, stack gas moisture content, stack gas molecular weight, and cross-sectional area of duct.

3.3 SCAQMD METHOD 3.1 – GAS ANALYSIS FOR DRY MOLECULAR WEIGHT AND EXCESS AIR

Leachate and condensate vapor gases were analyzed by GC for O₂ and CO₂.

3.4 SCAQMD METHOD 4.1 – DETERMINATION OF MOISTURE CONTENT IN STACK GASES

Moisture was measured using a wet bulb/dry bulb and calculated with a psychrometric chart.

3.5 SCAQMD METHOD 307-91 – HYDROGEN SULFIDE AND REDUCED SULFUR COMPOUNDS

Samples for determination of hydrogen sulfide and speciated reduced sulfur compounds were collected in Summa canisters. The samples were analyzed by GC/SCD by AtmAA, Inc., in Calabasas, California, following SCAQMD Method 307-91 protocol. The samples are analyzed within 24 hours of sampling.

3.6 EPA METHOD TO-15 – VOLATILES AND HYDROCARBON COLLECTED IN SUMMA CANISTER

Samples were collected in glass silicate lined Summa canisters. The samples were analyzed by AtmAA Inc., located in Calabasas, California for volatile organics listed in SCAQMD Rule 1150.1 Table 1 list.

Sampling Procedure:

One summa can per location was filled with sample gas using an evacuated cylinder. The sampling probe was connected to the can with Teflon tubing. The samples were collected at a fixed point halfway into the sampling duct.

4.0 RESULTS

The emission results are presented in Tables 4-1 and 4-2. Site schematics are presented in Appendix A.1.

**TABLE 4-1
 H₂S AND TOTAL REDUCED SULFUR RESULTS
 CHIQUITA CANYON LANDFILL
 LEACHATE AND CONDENSATE VAPOR SAMPLING
 MARCH 30, 2026**

Parameter/Units	Parnel	Zeeco	Hero	Tank Farm 13	Canyon D	Flare Station Pre-H ₂ S	Flare Station Post-H ₂ S
O₂, %	9.80	5.67	5.00	21.42	20.88	6.07	5.02
CO₂, %	29.82	46.03	45.62	1.65	1.32	35.54	39.00
N₂, %	40.62	23.97	26.30	76.85	77.04	25.39	21.74
H₂O, %	5.00	3.81	4.47	0.91	0.87	2.43	2.65
Flow Rate, scfm	2,306	1,115	1,923	259	190	1,728	1,706
Temperature, °F	110	106	116	96	94	113	110
Sulfur Compounds							
H ₂ S, ppm	102	159	124	<.08	0.13	165	186
Carbonyl Sulfide, ppm	<0.50	<2.00	<2.00	<.08	<.08	<.80	<0.80
Methyl Mercaptan, ppm	108.0	344.0	325	0.34	0.79	105	108
Ethyl Mercaptan, ppm	1.68	3.72	3.62	<.08	<.08	1.26	1.37
Dimethyl Sulfide, ppm	334.0	975	924	14.67	5.19	363	351
Carbon Disulfide, ppm	<0.50	<2.00	<2.00	<.08	<0.08	<0.80	<0.80
i-Propyl Mercaptan, ppm	1.33	2.54	2.32	<.08	<0.08	1.91	1.88
t-Butyl Mercaptan, ppm	<0.50	<2.00	<2.00	<.08	<0.08	<0.80	<0.80
n-Propyl Mercaptan, ppm	4.69	10.80	10.8	0.12	<0.08	3.88	4.03
s-Butyl Mercaptan, ppm	4.78	11.20	10.7	<.08	<0.08	4.87	4.85
i-Butyl Mercaptan, ppm	<0.50	<2.00	<2.00	0.34	<0.08	<0.80	<0.80
Dimethyl Disulfide, ppm	1.50	7.52	5.76	<.08	<0.08	2.78	2.51
Tetrahydrothiophene, ppm	1.90	7.34	6.81	<.08	<0.08	2.54	2.32
Unidentified S Compounds, ppm	11.20	29.5	21.4	0.1	<0.08	9.88	9.77
Total Sulfur Compounds:							
Total Sulfur, ppm	572.32	1557.10	1,439.64	15.56	6.11	662.39	672.72

**TABLE 4-2
 TRACE ORGANICS SPECIES RESULTS
 CHIQUITA CANYON LANDFILL
 LEACHATE AND CONDENSATE VAPOR SAMPLING
 MARCH 30, 2026**

Sample Location:	Parnel	Zeeco	Hero	Tank Farm 13	Canyon D	Flare Station Pre-H ₂ S	Flare Station Post H ₂ S
Test No.:	1	1	1	1	1	1	1
Start Time:	7:30	7:30	8:10	8:45	8:45	9:20	9:20
Flow Rate, scfm:	2306	1115	1923	259	190	1,728	1,706
Species	ppb	ppb	ppb	ppb	ppb	ppb	ppb
Hydrogen sulfide:	102,300	158,500	123,500	< 80	< 80	165,000	185,500
Benzene:	79,300	207,000	146,000	1,510	420	82,200	92,900
Benzyl Chloride:	< 17,900	< 17,900	< 17,900	< 50	< 50	< 17,900	< 17,900
Chlorobenzene:	< 20,200	< 20,200	< 20,200	< 50	< 50	< 20,200	< 20,200
Dichlorobenzenes*:	< 30,900	< 30,900	< 30,900	78.9	< 70	< 30,900	< 30,900
1,1-dichloroethane:	< 22,900	< 22,900	< 22,900	< 60	< 60	< 22,900	< 22,900
1,2-dichloroethane:	< 22,900	< 22,900	< 22,900	< 60	< 60	< 22,900	< 22,900
1,1-dichloroethylene:	< 23,400	< 23,400	< 23,400	< 60	< 60	< 23,400	< 23,400
Dichloromethane:	< 53,400	< 53,400	< 53,400	< 125	< 125	< 53,400	< 53,400
1,2-dibromoethane:	< 12,100	< 12,100	< 12,100	< 30	< 30	< 12,100	< 12,100
Perchloroethylene:	< 13,700	< 13,700	< 13,700	< 30	< 30	< 13,700	< 13,700
Carbon Tetrachloride:	< 29,500	< 29,500	< 29,500	< 70	< 70	< 29,500	< 29,500
Toluene:	< 24,600	26,600	< 24,600	245	258	< 24,600	< 24,600
1,1,1-trichloroethane:	< 17,000	< 17,000	< 17,000	< 40	< 40	< 17,000	< 17,000
Trichloroethene:	< 17,300	< 17,300	< 17,300	< 40	< 40	< 17,300	< 17,300
Chloroform:	< 19,000	< 19,000	< 19,000	< 45	< 45	< 19,000	< 19,000
Vinyl Chloride:	< 18,200	< 18,200	< 18,200	< 45	< 45	< 18,200	< 18,200
M+P-xylenes:	< 21,400	< 21,400	< 21,400	298	104.0	< 21,400	< 21,400
O-xylene:	< 21,400	< 21,400	< 21,400	128	43.8	< 21,400	< 21,400

< - indicates that the species was not detected in the sample above the analytical detection limit for this species.

The values reported is the detection limit for the species and the actual concentration is lower.

*Total amount containing meta, para, and ortho isomers.

APPENDIX A TEST DATA

Appendix A.1 Sample Location Data

METHOD 1 DATA SHEET INLET SAMPLE LOCATION

Client: SCS Field Services

Date: 3/30/26

Location: Chiquita Zeeco Flare Inlet

Performed By: SJ, AD, RM

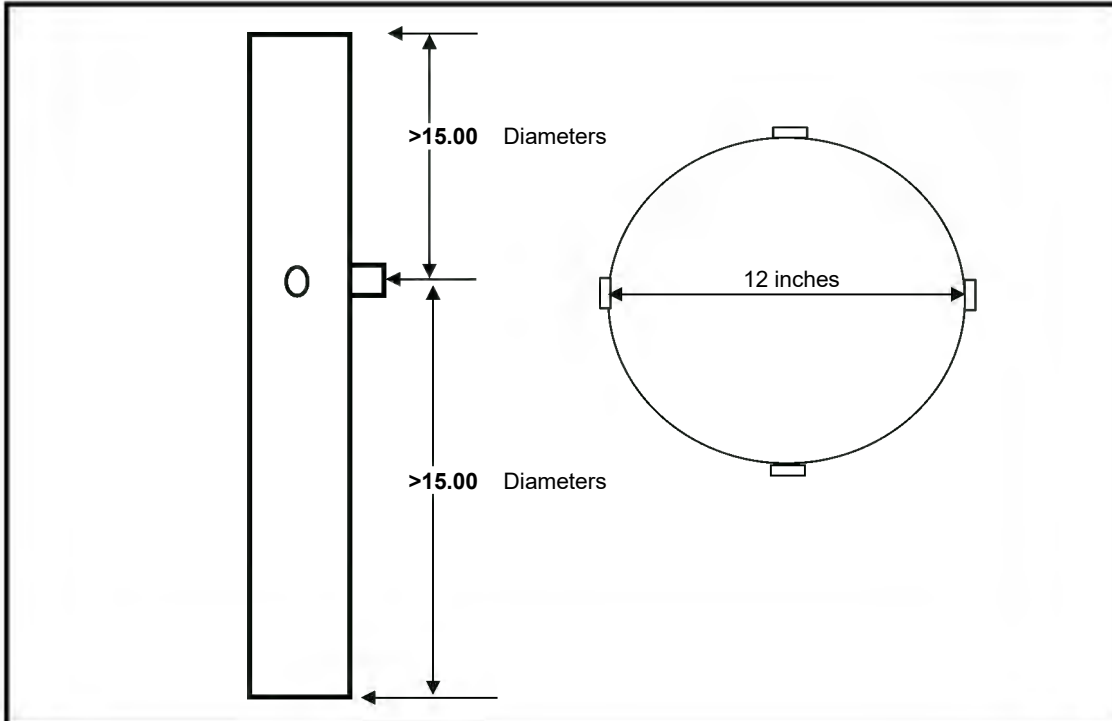

Diameter (inches)	12.00			
Upstream (inches)	180.00	Sample Point	% of Diameter	Dist from Wall (inches)
Downstream (inches)	180.00	1	4.4	0.5
Coupling (in.)	0.00	2	14.6	1.8
Stack Area (ft ²)	0.785	3	29.6	3.6
		4	70.4	8.4
		5	85.4	10.2
		6	95.6	11.5



METHOD 1 DATA SHEET INLET SAMPLE LOCATION

Client: SCS Field Services

Date: 3/30/26

Location: Chiquita Parnel Inlet

Performed By: SJ, AD, RM

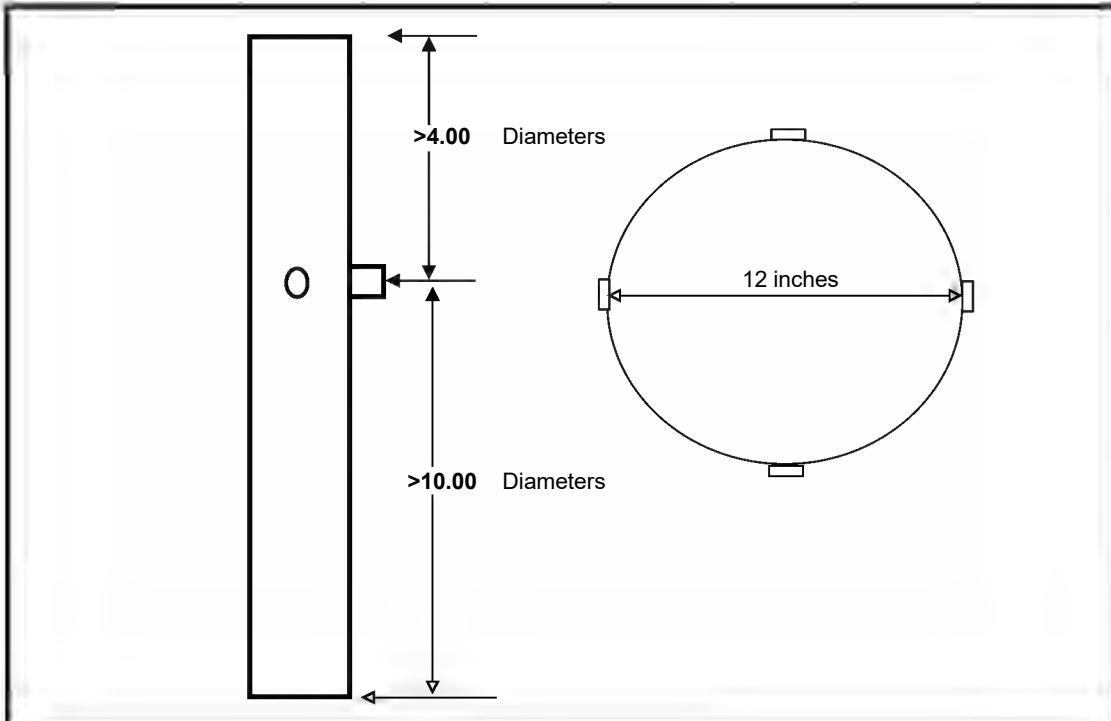

METHOD 1 DATA SHEET INLET SAMPLE LOCATION

Client: SCS Field Services

Date: 3/30/26

Location: Hero

Performed By: SJ, AD, RM

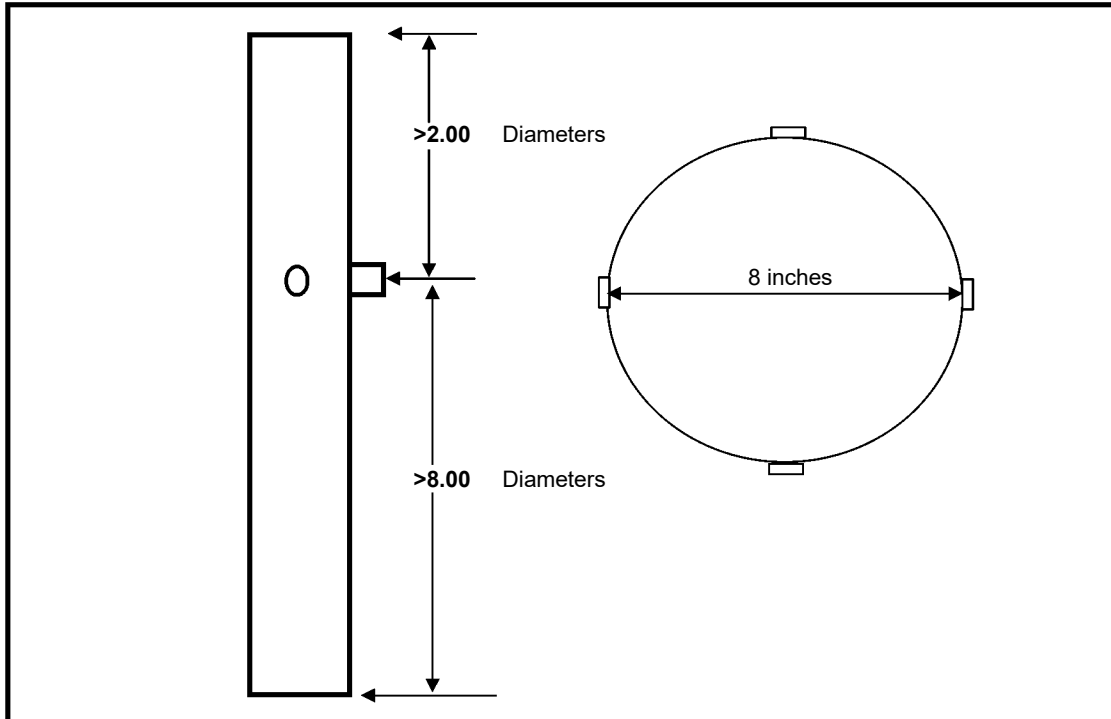

Diameter (inches)	8.00
Upstream (inches)	64.00
Downstream (inches)	16.00
Coupling (in.)	0.00
Stack Area (ft ²)	0.349

Sample Point	% of Diameter	Dist from Wall (inches)	Dist from Port (inches)
1	4.4	0.5	0.5
2	14.6	1.2	1.2
3	29.6	2.4	2.4
4	70.4	5.6	5.6
5	85.4	6.8	6.8
6	95.6	5.5	5.5



METHOD 1 DATA SHEET INLET SAMPLE LOCATION



Client: SCS Field Services

Date: 3/30/26

Location: Chiquita Tank Farm 13

Performed By: SJ, AD, RM

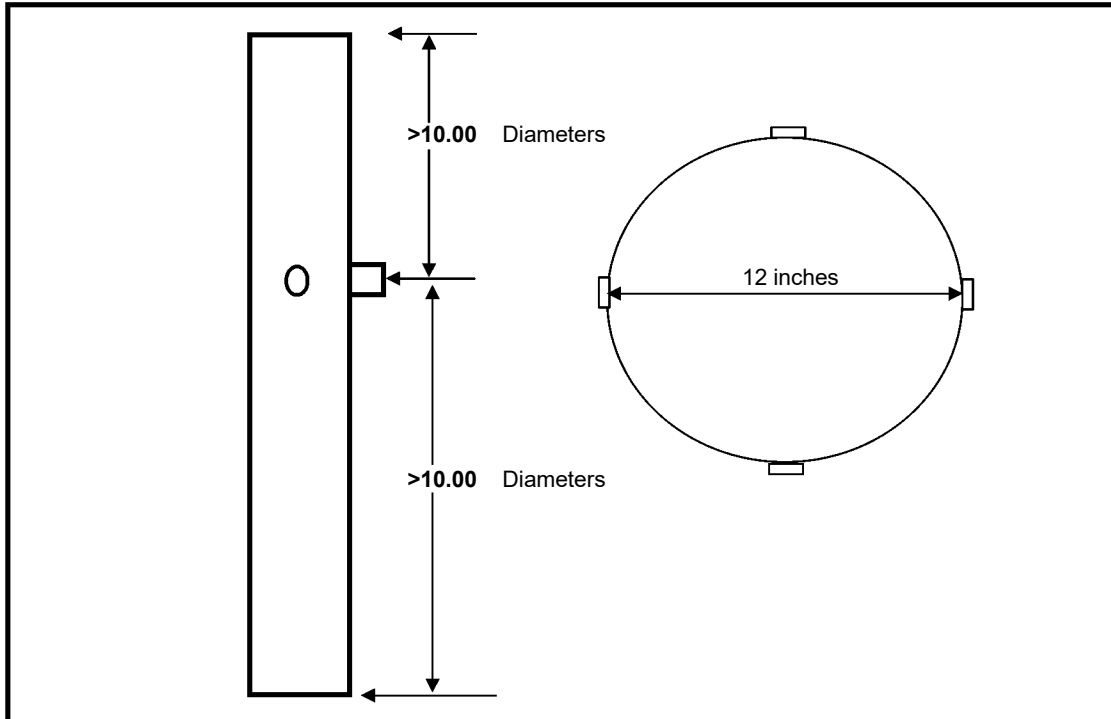

Diameter (inches)	12.00
Upstream (inches)	120.00
Downstream (inches)	120.00
Coupling (in.)	0.00
Stack Area (ft ²)	0.785

Sample Point	% of Diameter	Dist from Wall (inches)	Dist from Port (inches)
1	4.4	0.5	0.5
2	14.6	1.8	1.8
3	29.6	3.6	3.6
4	70.4	8.4	8.4
5	85.4	10.2	10.2
6	95.6	11.5	11.5

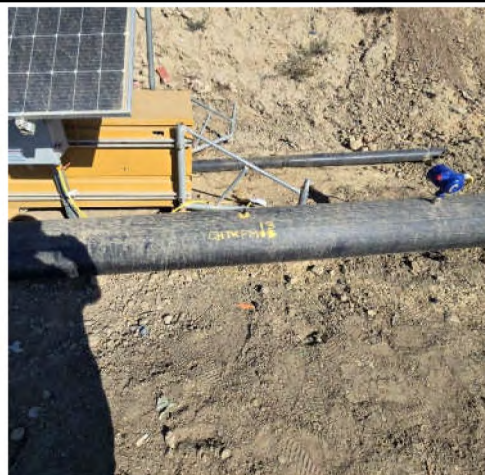

METHOD 1 DATA SHEET INLET SAMPLE LOCATION

Client: SCS Field Services

Date: 3/30/26

Location: Chiquita TF Canyon D

Performed By: SJ, AD, RM

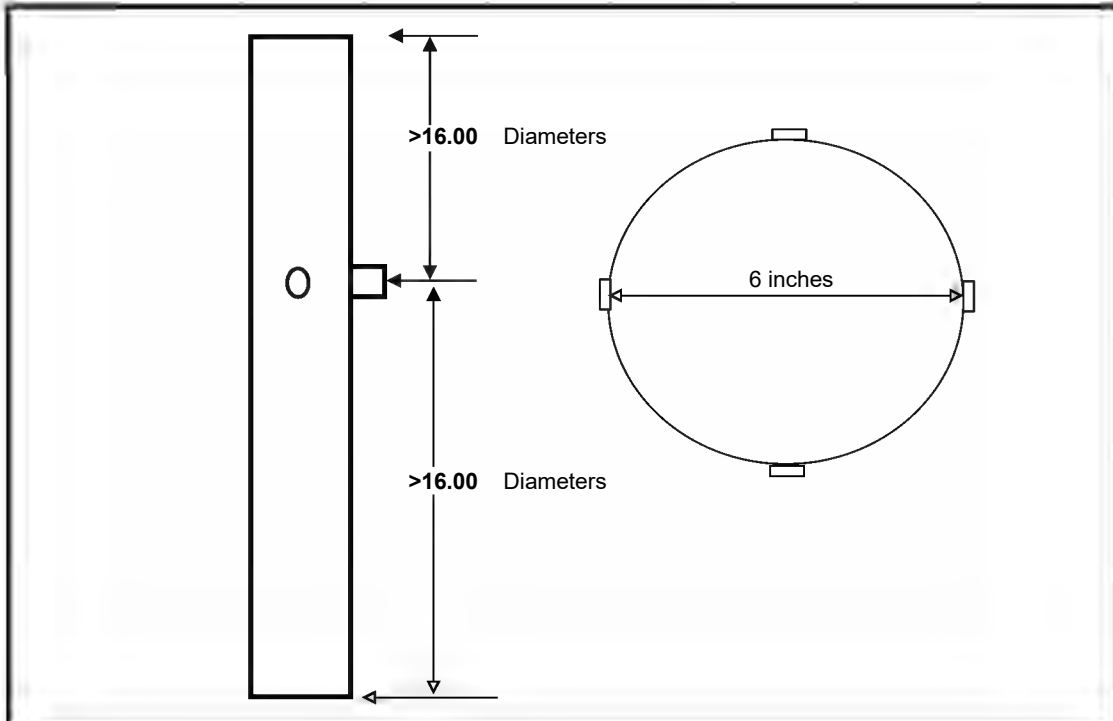

Diameter (inches)	6.00
Upstream (inches)	96.00
Downstream (inches)	96.00
Coupling (in.)	0.00
Stack Area (ft ²)	0.196

Sample Point	% of Diameter	Dist from Wall (inches)	Dist from Port (inches)
1	4.4	0.5	0.5
2	14.6	0.9	0.9
3	29.6	1.8	1.8
4	70.4	4.2	4.2
5	85.4	5.1	5.1
6	95.6	5.7	5.7

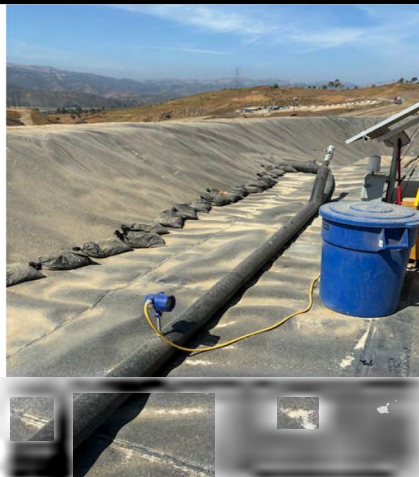

METHOD 1 DATA SHEET INLET SAMPLE LOCATION

Client: SCS Field Services

Date: 3/30/26

Location: Flare Station Pre-H2S

Performed By: SJ, AD, RM

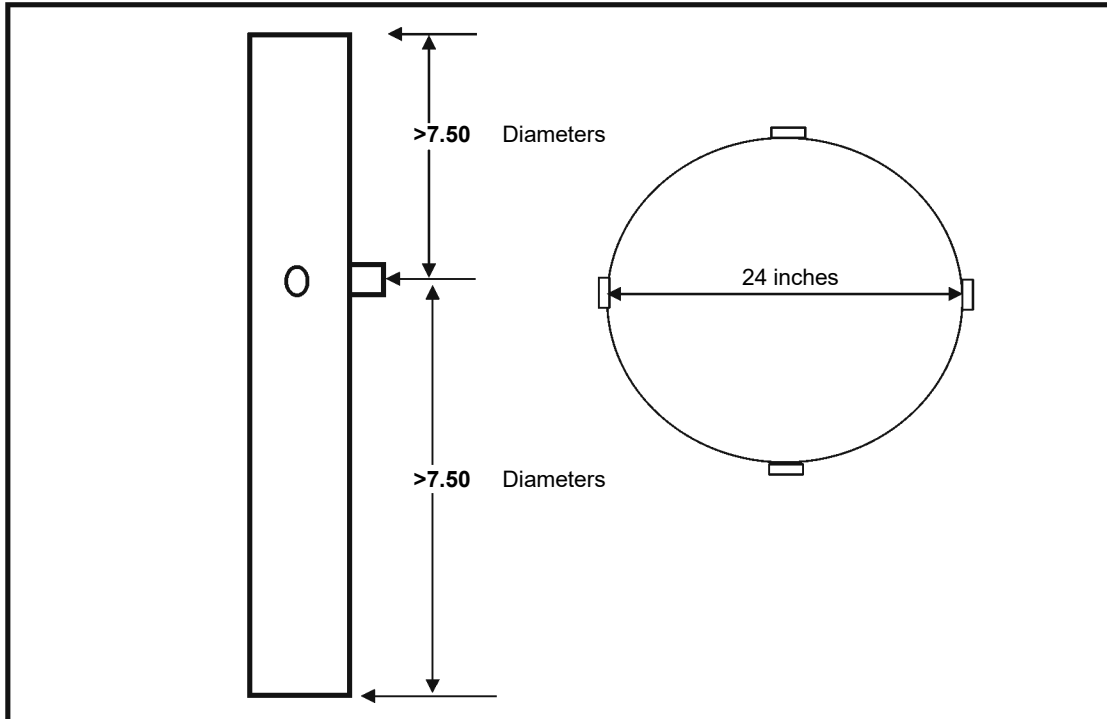

Diameter (inches)	24.00	Sample Point	% of Diameter	Dist from Wall (inches)	Dist from Port (inches)
Upstream (inches)	180.00	1	3.2	0.8	0.8
Downstream (inches)	180.00	2	10.5	2.5	2.5
Coupling (in.)	0.00	3	19.4	4.7	4.7
Stack Area (ft ²)	3.142	4	32.3	7.8	7.8
		5	67.7	16.2	16.2
		6	80.6	19.3	19.3
		7	89.5	21.5	21.5
		8	96.8	23.2	23.2



METHOD 1 DATA SHEET INLET SAMPLE LOCATION

Client: SCS Field Services

Date: 3/30/26

Location: Flare Station Post-H2S

Performed By: SJ, AD, RM

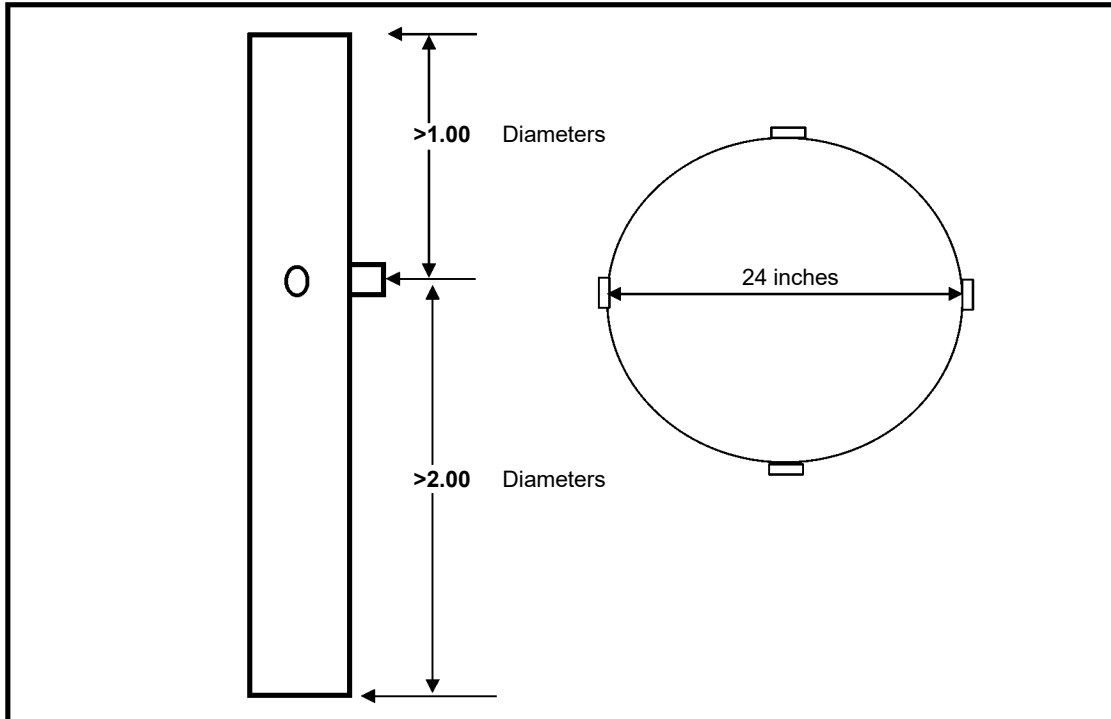

Diameter (inches)	24.00			
Upstream (inches)	48.00	Sample Point	% of Diameter	Dist from Wall (inches)
Downstream (inches)	24.00	1	3.2	0.8
Coupling (in.)	0.00	2	10.5	2.5
Stack Area (ft ²)	3.142	3	19.4	4.7
		4	32.3	7.8
		5	67.7	16.2
		6	80.6	19.3
		7	89.5	21.5
		8	96.8	23.2



Appendix A.2

Velocity, Moisture and Flow Rate Data

MONTROSE AQS
Duct Moisture by Wet bulb/Dry bulb Measurements

Facility: Chiquita Canyon Landfill
 CEM I.D. : T-4

TEST DATE: March 30, 2026

BY: PSJ

$$B_{ws} = \frac{e''}{P_a}$$

$$e_a = e'' \frac{(P_a - e'') [T_{dry} - T_{wet}]}{2800 - 1.3 \times T_{wet}}$$

	P _{bar}	Static Pressure (in. of H ₂ O)	P _a	T _{dry}	T _{wet}	e _a	B _{ws}	e''
ZEECO	28.91	-17.00	27.662	110	93	1.3823	5.00	1.54797
Parnel	28.91	-30.00	26.7061	106	85	1.016187	3.81	1.215223
Hero	28.91	-9.30	28.2282	116	92	1.262598	4.47	1.501902
Tank Farm 13	28.91	-0.030	28.9098	96	63	0.261987	0.91	0.605624
Canyon D	28.91	-0.048	28.9085	94	62	0.250919	0.87	0.584219
Flare Station Pre	28.91	-0.170	28.8995	113	80	0.703105	2.43	1.044066
Flare Station Post	28.91	3.650	29.1804	110	81	0.773872	2.65	1.076324

**DATA AND WORKSHEET
RUN NUMBER 1**

TEST CONSTANTS				
Station: Chiquita Canyon Landfill				
Unit: ZEECO				
Performed By: SJ, AD, RM				
Cp: 0.84				
T _{ref} : 60 °F				
Stack Area: 0.785 ft ²				
TEST VARIABLES				
Start Date: SJ, AD, RM				
Start/End Time: 7:30 8:00				
Test Condition: Normal				
Barom. Pressure: 28.91				
P _{stack} : -17.00 iwg				
P _{stack} : 27.66 "Hg				
MW Wet: 29.70 lb/lb-mole				
MW Dry: 30.32 lb/lb-mole				
Moisture				
Moisture Content: 5.00 % From WbDb				
Fuel Gas Composition Data				
O ₂ : 9.80 % From canister analysis				
CO ₂ : 29.82 % From canister analysis				
N ₂ : 40.62 % From canister analysis				
CH ₄ : 16.80 % From canister analysis				
METHOD 2.1 DATA				
Point	dP (in. H ₂ O)	sqrt(dP)	Temp °F	Vel. (fps)
1	0.970	0.9849	110	58.81
2	0.930	0.9644	110	57.59
3	0.960	0.9798	110	58.51
4	0.990	0.9950	110	59.42
5	1.000	1.0000	110	59.71
6	0.940	0.9695	110	57.90
1	0.920	0.9592	110	57.28
2	0.950	0.9747	110	58.20
3	0.930	0.9644	110	57.59
4	0.910	0.9539	110	56.96
5	0.930	0.9644	110	57.59
6	0.900	0.9487	110	56.65
Average	0.9439	0.9716	110	58.02
Flow Rate: 2,734 wacfm				
Flow Rate: 2,306 scfm				
Flow Rate: 2,191 dscfm				

**DATA AND WORKSHEET
RUN NUMBER 1**

TEST CONSTANTS				
Station: Chiquita Canyon Landfill				
Unit: Parnel				
Performed By: SJ, AD, RM				
Cp: 0.84				
T _{ref} : 60 °F				
Stack Area: 0.785 ft ²				
TEST VARIABLES				
Start Date: SJ, AD, RM				
Start/End Time: 7:30 8:00				
Test Condition: Normal				
Barom. Pressure: 28.91				
P _{stack} : -30.0 iwg				
P _{stack} : 26.71 "Hg				
MW Wet: 30.79 lb/lb-mole				
MW Dry: 31.29 lb/lb-mole				
Moisture				
Moisture Content: 3.81 % From WbDb				
Fuel Gas Composition Data				
O ₂ : 5.67 % From canister analysis				
CO ₂ : 46.03 % From canister analysis				
N ₂ : 23.97 % From canister analysis				
CH ₄ : 15.72 % From canister analysis				
METHOD 2.1 DATA				
Point	dP (in. H ₂ O)	sqrt(dP)	Temp °F	Vel. (fps)
1	0.220	0.4690	106	27.90
2	0.270	0.5196	106	30.91
3	0.240	0.4899	106	29.14
4	0.260	0.5099	106	30.33
5	0.270	0.5196	106	30.91
6	0.240	0.4899	106	29.14
1	0.230	0.4796	106	28.53
2	0.230	0.4796	106	28.53
3	0.240	0.4899	106	29.14
4	0.220	0.4690	106	27.90
5	0.200	0.4472	106	26.60
6	0.210	0.4583	106	27.26
Average	0.2354	0.4851	106	28.86
Flow Rate: 1,360 wacfm				
Flow Rate: 1,115 scfm				
Flow Rate: 1,073 dscfm				

**DATA AND WORKSHEET
RUN NUMBER 1**

TEST CONSTANTS				
Station: Chiquita Canyon Landfill				
Unit: Hero				
Performed By: SJ, AD, RM				
Cp: 0.84				
T _{ref} : 60 °F				
Stack Area: 0.349 ft ²				
TEST VARIABLES				
Start Date: SJ, AD, RM				
Start/End Time: 8:10 8:40				
Test Condition: Normal				
Barom. Pressure: 28.91				
P _{stack} : -9.3 iwg				
P _{stack} : 28.23 "Hg				
MW Wet: 30.61 lb/lb-mole				
MW Dry: 31.20 lb/lb-mole				
Moisture				
Moisture Content: 4.47 % From WbDb				
Fuel Gas Composition Data				
O ₂ : 5.00 % From canister analysis				
CO ₂ : 45.62 % From canister analysis				
N ₂ : 26.30 % From canister analysis				
CH ₄ : 13.53 % From canister analysis				
METHOD 2.1 DATA				
Point	dP (in. H ₂ O)	sqrt(dP)	Temp °F	Vel. (fps)
1	3.460	1.8601	116	108.88
2	3.550	1.8841	116	110.29
3	3.610	1.9000	116	111.22
4	3.580	1.8921	116	110.75
5	3.240	1.8000	116	105.36
6	3.270	1.8083	116	105.85
1	3.370	1.8358	116	107.46
2	3.520	1.8762	116	109.82
3	3.450	1.8574	116	108.72
4	3.380	1.8385	116	107.61
5	3.120	1.7664	116	103.39
6	3.160	1.7776	116	104.05
Average	3.3907	1.8414	116	107.78
Flow Rate: 2,257 wacfm				
Flow Rate: 1,923 scfm				
Flow Rate: 1,837 dscfm				

**DATA AND WORKSHEET
RUN NUMBER 1**

TEST CONSTANTS				
Station: Chiquita Canyon Landfill				
Unit: Tank Farm 13				
Performed By: SJ, AD, RM				
Cp: 0.84				
T _{ref} : 60 °F				
Stack Area: 0.785 ft ²				
TEST VARIABLES				
Start Date: SJ, AD, RM				
Start/End Time: 8:45 9:15				
Test Condition: Normal				
Barom. Pressure: 28.91				
P _{stack} : -0.030 iwg				
P _{stack} : 28.91 "Hg				
MW Wet: 29.01 lb/lb-mole				
MW Dry: 29.11 lb/lb-mole				
Moisture				
Moisture Content: 0.91 % From WbDb				
Fuel Gas Composition Data				
O ₂ : 21.42 % From canister analysis				
CO ₂ : 1.65 % From canister analysis				
N ₂ : 76.85 % From canister analysis				
CH ₄ : <0.10 % From canister analysis				
METHOD 2.1 DATA				
Point	dP (in. H ₂ O)	sqrt(dP)	Temp °F	Vel. (fps)
1	0.0120	0.1095	96	6.39
2	0.0110	0.1049	96	6.12
3	0.0100	0.1000	96	5.84
4	0.0095	0.0975	96	5.69
5	0.0097	0.0985	96	5.75
6	0.0094	0.0970	96	5.66
1	0.0096	0.0980	96	5.72
2	0.0099	0.0995	96	5.81
3	0.0110	0.1049	96	6.12
4	0.0130	0.1140	96	6.66
5	0.0120	0.1095	96	6.39
6	0.0140	0.1183	96	6.91
Average	0.0109	0.1043	96	6.09
Flow Rate: 287 wacfm				
Flow Rate: 259 scfm				
Flow Rate: 257 dscfm				

**DATA AND WORKSHEET
RUN NUMBER 1**

TEST CONSTANTS				
Station: Chiquita Canyon Landfill				
Unit: Canyon D				
Performed By: SJ, AD, RM				
Cp: 0.84				
T _{ref} : 60 °F				
Stack Area: 0.196 ft ²				
TEST VARIABLES				
Start Date: SJ, AD, RM				
Start/End Time: 8:45 9:15				
Test Condition: Normal				
Barom. Pressure: 28.91				
P _{stack} : -0.048 iwg				
P _{stack} : 28.91 "Hg				
MW Wet: 28.80 lb/lb-mole				
MW Dry: 28.90 lb/lb-mole				
Moisture				
Moisture Content: 0.87 % From WbDb				
Fuel Gas Composition Data				
O ₂ : 20.88 % From canister analysis				
CO ₂ : 1.32 % From canister analysis				
N ₂ : 77.04 % From canister analysis				
CH ₄ : 0.41 % From canister analysis				
METHOD 2.1 DATA				
Point	dP (in. H ₂ O)	sqrt(dP)	Temp °F	Vel. (fps)
1	0.093	0.3050	94	17.83
2	0.093	0.3050	94	17.83
3	0.091	0.3017	94	17.64
4	0.092	0.3033	94	17.74
5	0.096	0.3098	94	18.12
6	0.095	0.3082	94	18.02
1	0.091	0.3017	94	17.64
2	0.089	0.2983	94	17.45
3	0.092	0.3033	94	17.74
4	0.094	0.3066	94	17.93
5	0.096	0.3098	94	18.12
6	0.093	0.3050	94	17.83
Average	0.0929	0.3048	94	17.82
Flow Rate: 210 wacfm				
Flow Rate: 190 scfm				
Flow Rate: 189 dscfm				

**DATA AND WORKSHEET
RUN NUMBER 1**

TEST CONSTANTS				
Station: Chiquita Canyon Landfill				
Unit: Flare Station Pre-H2S				
Performed By: SJ, AD, RM				
Cp: 0.84				
T _{ref} : 60 °F				
Stack Area: 3.142 ft ²				
TEST VARIABLES				
Start Date: SJ, AD, RM				
Start/End Time: 9:20 9:50				
Test Condition: Normal				
Barom. Pressure: 28.91				
P _{stack} : -0.17 iwg				
P _{stack} : 28.90 "Hg				
MW Wet: 28.52 lb/lb-mole				
MW Dry: 28.79 lb/lb-mole				
Moisture				
Moisture Content: 2.43 % From WbDb				
Fuel Gas Composition Data				
O ₂ : 6.07 % From canister analysis				
CO ₂ : 35.54 % From canister analysis				
N ₂ : 25.39 % From canister analysis				
CH ₄ : 25.61 % From canister analysis				
METHOD 2.1 DATA				
Point	dP (in. H ₂ O)	sqrt(dP)	Temp °F	Vel. (fps)
1	0.028	0.1673	113	10.00
2	0.024	0.1549	113	9.26
3	0.029	0.1703	113	10.18
4	0.024	0.1549	113	9.26
5	0.031	0.1761	113	10.52
6	0.035	0.1871	113	11.18
7	0.033	0.1817	113	10.86
8	0.032	0.1789	113	10.69
1	0.036	0.1897	113	11.34
2	0.033	0.1817	113	10.86
3	0.030	0.1732	113	10.35
4	0.034	0.1844	113	11.02
5	0.039	0.1975	113	11.80
6	0.031	0.1761	113	10.52
7	0.028	0.1673	113	10.00
8	0.025	0.1581	113	9.45
Average	0.0306	0.1749	113	10.46
Flow Rate: 1,971 wacfm				
Flow Rate: 1,728 scfm				
Flow Rate: 1,686 dscfm				

**DATA AND WORKSHEET
RUN NUMBER 1**

TEST CONSTANTS				
Station: Chiquita Canyon Landfill				
Unit: Flare Station Post-H2S				
Performed By: SJ, AD, RM				
Cp: 0.84				
T _{ref} : 60 °F				
Stack Area: 3.142 ft ²				
TEST VARIABLES				
Start Date: SJ, AD, RM				
Start/End Time: 9:20 9:50				
Test Condition: Normal				
Barom. Pressure: 28.91				
P _{stack} : 3.65 iwg				
P _{stack} : 29.18 "Hg				
MW Wet: 29.00 lb/lb-mole				
MW Dry: 29.30 lb/lb-mole				
Moisture				
Moisture Content: 2.65 % From WbDb				
Fuel Gas Composition Data				
O ₂ : 5.02 % From canister analysis				
CO ₂ : 39.00 % From canister analysis				
N ₂ : 21.74 % From canister analysis				
CH ₄ : 27.79 % From canister analysis				
METHOD 2.1 DATA				
Point	dP (in. H ₂ O)	sqrt(dP)	Temp °F	Vel. (fps)
1	0.023	0.1517	110	8.92
2	0.029	0.1703	110	10.02
3	0.033	0.1817	110	10.69
4	0.038	0.1949	110	11.47
5	0.037	0.1924	110	11.32
6	0.030	0.1732	110	10.19
7	0.035	0.1871	110	11.01
8	0.030	0.1732	110	10.19
1	0.029	0.1703	110	10.02
2	0.023	0.1517	110	8.92
3	0.027	0.1643	110	9.67
4	0.034	0.1844	110	10.85
5	0.036	0.1897	110	11.16
6	0.033	0.1817	110	10.69
7	0.025	0.1581	110	9.30
8	0.020	0.1414	110	8.32
Average	0.0299	0.1729	110	10.17
Flow Rate: 1,917 wacfm				
Flow Rate: 1,706 scfm				
Flow Rate: 1,661 dscfm				

FLUE GAS VELOCITY DATASHEET

CLIENT: WASTE CONNECTIONS PERFORMED BY: SS/AD/EM
 LOCATION: CHOWITA BAR. PRESSURE: 28.91
 UNIT: ZERO INLET STATIC PRESSURE: -17.0
 TEST DATE: 2/26/26 TC READOUT ID: 3+243
 TEST NUMBER: 1 TC ID: W/B/30
 LEAK CHECK PRE- POST- PITOT TUBE ID: 30
 ΔP INDICATOR TYPE: ELECTRONIC PITOT TUBE COEFFICIENT: 0.84
 ΔP INDICATOR ID: ADM 850A9 ZERO: LEVEL:

Cycle Time	Port	Point	Vel. Head in. H ₂ O	Temp., °F	Cycle Time	Port	Point	Vel. Head in. H ₂ O	Temp., °F
2'	T	1	0.97	110	4'	S	1	0.92	110
0'		2	0.93	110	1'		2	0.95	110
1		3	0.96	110	2		3	0.93	110
3		4	0.99	110	1		4	0.91	110
4		5	1.00	110	7		5	0.93	110
6		6	0.94	110	3		6	1.90	110
			W3 =	93					
		(30)	D3 =	110					

Comments: _____

FLUE GAS VELOCITY DATASHEET

CLIENT: WASTE CONNECTIONS PERFORMED BY: SE/AD/RM
 LOCATION: CHILQUITA BAR. PRESSURE: 29.91
 UNIT: TANK FARM 13 STATIC PRESSURE: -0.030
 TEST DATE: 3/30/24 TC READOUT ID: PTC 43
 TEST NUMBER: 1 TC ID: WB/30
 LEAK CHECK PRE- POST- PITOT TUBE ID: 30
 ΔP INDICATOR TYPE: ELECTRONIC PITOT TUBE COEFFICIENT: 0.84
 ΔP INDICATOR ID: ADM 850 #7 ZERO: LEVEL:

<u>Cy 1</u> Time	Port	Point	Vel. Head in. H ₂ O	Temp., °F	<u>Cy 4</u> Time	Port	Point	Vel. Head in. H ₂ O	Temp., °F
2 ⁰	5	1	0.0120	96	6 ⁰	5	1	0.0096	96
7		2	0.0110	94	4		2	0.0099	96
1		3	0.0100	96	1		3	0.0110	96
4		4	0.0095	96	5		4	0.0130	96
0		5	0.0097	96	0		5	0.0120	96
3		6	0.0094	96	2		6	0.0140	96
			WB =	63					
		(30)	DP =	96					

Comments: _____

FLUE GAS VELOCITY DATASHEET

CLIENT: WASTE CONNECTIONS PERFORMED BY: XL/AD/RM
 LOCATION: CAHQUITA BAR. PRESSURE: 28.91
 UNIT: FLAME STATION H2S PRE STATIC PRESSURE: -0.17
 TEST DATE: 3/30/20 TC READOUT ID: PTC 43
 TEST NUMBER: 1 TC ID: WB/30
 LEAK CHECK PRE- POST- PITOT TUBE ID: 30
 ΔP INDICATOR TYPE: ELECTRONIC PITOT TUBE COEFFICIENT: 0.87
 ΔP INDICATOR ID: ADM 850 #9 ZERO: LEVEL:

Cycle Time	A Port	Point	Vel. Head in. H ₂ O	Temp., °F	Cycle Time	B Port	Point	Vel. Head in. H ₂ O	Temp., °F
2°		1	0.028	113	5°		1	0.032	113
7		2	0.024	113	3		2	0.033	113
7		3	0.027	113	1		3	0.030	113
6		4	0.027	113	2		4	0.031	113
3		5	0.031	113	1		5	0.037	113
5		6	0.035	113	2		6	0.031	113
1		7	0.033	113	0		7	0.029	113
4		8	0.032	113	3		8	0.025	113
			WB =	80					
		(30)	PIT =	113					

Comments: _____

Appendix A.3

Organics and Sulfur Field and Laboratory Data

LEACHATE TANK HEADSPACE SAMPLING DATA

Client/Facility: WASTE CONNECTIONS Date: 3/30/26
 Unit/Location: ZEED INLET Performed By: SS/AO/KM
 Barometric Pressure 28.71 Ambient Temperature 68°

SUMMA CANISTER DATA

Test No.		1	
Canister ID		0568	
		Time	Vacuum
Pre-Test Leak Check	Start	0700	30
Pre-Test Leak Check	Stop	0710	30
Sample Collection	Start	0730	30
	10	0740	21
	20	0800	15
	30	0800	5
Sample Collection	Stop		
Post-Test Leak Check	Start	10:00	5
Post-Test Leak Check	Stop	10:20	5

FLOWRATE DATA

Diameter: 12"
 Upstream: 180"
 Downstream: 180"
 Flow Rate: 2298
 Wet bulb: 93
 Dry bulb: 110

TEDLAR BAG DATA

Start: NA
 Stop: NA
 Bag ID: NA

LEACHATE TANK HEADSPACE SAMPLING DATA

Client/Facility: WASTE CONNECTIONS Date: 3/30/26
 Unit/Location: PANEL INLET Performed By: ET/AD/EM
 Barometric Pressure 28.41 Ambient Temperature 68

SUMMA CANISTER DATA

Test No.		1	
Canister ID		246036	
		Time	Vacuum
Pre-Test Leak Check	Start	0700	30
Pre-Test Leak Check	Stop	0710	30
Sample Collection	Start	0730	30
	10	0746	21
	20	0740	14
	30	0800	5
Sample Collection	Stop		
Post-Test Leak Check	Start	1000	5
Post-Test Leak Check	Stop	1020	5

FLOWRATE DATA

Diameter: 12"
 Upstream: 120"
 Downstream: 48"
 Flow Rate: 1142
 Wet bulb: 10.85 98
 Dry bulb: 10.6

TEDLAR BAG DATA

Start: N/A
 Stop: N/A
 Bag ID: _____

LEACHATE TANK HEADSPACE SAMPLING DATA

Client/Facility: WASTE CONNECTIONS Date: 3/30/26
 Unit/Location: HEAD INLET Performed By: ST/AD/RM
 Barometric Pressure 28.91 Ambient Temperature 68'

SUMMA CANISTER DATA

Test No.		1	
Canister ID			
		Time	Vacuum
Pre-Test Leak Check	Start	0700	30
Pre-Test Leak Check	Stop	0710	30
Sample Collection	Start	0810	30
	10	0820	22
	20	0830	16
	30	0840	5
Sample Collection	Stop		
Post-Test Leak Check	Start	10:00	5
Post-Test Leak Check	Stop	10:20	5

FLOWRATE DATA

Diameter: 8"
 Upstream: 64"
 Downstream: 16"
 Flow Rate: 1918
 Wet bulb: 72
 Dry bulb: 116

TEDLAR BAG DATA

Start: N/A
 Stop: N/A
 Bag ID: _____

LEACHATE TANK HEADSPACE SAMPLING DATA

Client/Facility: WASTE CONNECTIONS Date: 3/30/26
 Unit/Location: TANK FARM 13 Performed By: ST/AB/PM
 Barometric Pressure 29.91 Ambient Temperature 68⁰

SUMMA CANISTER DATA

Test No.		1	
Canister ID			
		Time	Vacuum
Pre-Test Leak Check	Start	0740	30
Pre-Test Leak Check	Stop	0710	30
Sample Collection	Start	0845	30
10		0855	21
20		0905	16
30		0915	5
Sample Collection	Stop		
Post-Test Leak Check	Start	10:00	5
Post-Test Leak Check	Stop	10:20	5

FLOWRATE DATA

Diameter: 12"
 Upstream: 120"
 Downstream: 120"
 Flow Rate: 252
 Wet bulb: 63'
 Dry bulb: 96'

TEDLAR BAG DATA

Start: N/A
 Stop: N/A
 Bag ID: N/A

LEACHATE TANK HEADSPACE SAMPLING DATA

Client/Facility: WASTE CONNECTIONS Date: 3/30/26

Unit/Location: TANK FARM CANNON D Performed By: ST/AD/RM

Barometric Pressure 29.91 Ambient Temperature 68°

SUMMA CANISTER DATA

Test No.	1		
Canister ID			
		Time	Vacuum
Pre-Test Leak Check	Start	0700	30
Pre-Test Leak Check	Stop	0710	30
Sample Collection	Start	0815	30
		0855	23
		0905	15
		0915	5
Sample Collection	Stop		
Post-Test Leak Check	Start	10:00	5
Post-Test Leak Check	Stop	10:20	5

FLOWRATE DATA

Diameter: 6"

Upstream: 76"

Downstream: 76"

Flow Rate: 189

Wet bulb: 62°

Dry bulb: 74

TEDLAR BAG DATA

Start: N/A

Stop: N/A

Bag ID: N/A

LEACHATE TANK HEADSPACE SAMPLING DATA

Client/Facility: WASTE CONNECTIONS Date: 3/30/26

Unit/Location: FLARE STATION H2S PRE Performed By: ST/AD/KM

Barometric Pressure 26.91 Ambient Temperature 68°

SUMMA CANISTER DATA

Test No.	1		
Canister ID			
		Time	Vacuum
Pre-Test Leak Check	Start	0700	30
Pre-Test Leak Check	Stop	0710	30
Sample Collection	Start	0910	30
10		0930	21
20		0940	16
30		0950	5
Sample Collection	Stop		
Post-Test Leak Check	Start	10:00	5
Post-Test Leak Check	Stop	10:20	5

FLOWRATE DATA

Diameter: 24"

Upstream: 180"

Downstream: 180"

Flow Rate: N/A

Wet bulb: 80

Dry bulb: 113

TEDLAR/BAG DATA

Start: N/A

Stop: N/A

Bag ID: N/A

LEACHATE TANK HEADSPACE SAMPLING DATA

Client/Facility: WASTE CONNECTIONS Date: 2/10/01 ✱
 Unit/Location: FLAME STATION H2S POST Performed By: ST23/30/26
 Barometric Pressure 28.91 Ambient Temperature 68°

SUMMA CANISTER DATA

Test No.		1	
Canister ID			
		Time	Vacuum
Pre-Test Leak Check	Start	0700	30
Pre-Test Leak Check	Stop	0710	36
Sample Collection	Start	0920	30
10		0930	25
20		0940	16
30		0950	5
Sample Collection	Stop		
Post-Test Leak Check	Start	10:00	5
Post-Test Leak Check	Stop	1020	5

FLOWRATE DATA

Diameter: 24"
 Upstream: 48"
 Downstream: 24"
 Flow Rate: N/A
 Wet bulb: 81
 Dry bulb: 110

TEDLAR BAG DATA

Start: N/A
 Stop: N/A
 Bag ID: _____



LABORATORY ANALYSIS REPORT

Permanent Gases Analysis in Silco Canister Samples by Method ASTM D1946-90

Report Date: April 6, 2026
Client: Montrose AQS
Project Location: Waste Connections
Project No.: PROJ-066231
Date Received: March 30, 2026
Date Analyzed: March 30, 2026

ANALYSIS DESCRIPTION

Permanent gases were measured by thermal conductivity detection/gas chromatography (TCD/GC), ASTM D1946-90.

AtmAA Lab No.:	20896-17	20896-18	20896-19
Sample I.D.:	Zeeco Inlet	Parnel Inlet	Hero Inlet

<u>Components</u>	<i>(Concentration in %,v)</i>		
Nitrogen	40.62	23.97	26.30
Oxygen	9.80	5.67	5.00
Methane	16.80	15.72	13.53
Carbon dioxide	29.82	46.03	45.62
Hydrogen	1.49	4.82	4.75

The reported oxygen concentration includes any argon present in the sample. Calibration is based on a standard atmosphere containing 20.95% oxygen and 0.93% argon. The accuracy of permanent gas analysis by TCD/GC is +/- 2%, actual results are reported. Actual analysis results are reported on a "wet" basis.



Brian W. Fung
Laboratory Director



LABORATORY ANALYSIS REPORT

Permanent Gases Analysis in Silco Canister Samples by Method ASTM D1946-90

Report Date: April 6, 2026
Client: Montrose AQS
Project Location: Waste Connections
Project No.: PROJ-066231
Date Received: March 30, 2026
Date Analyzed: March 30, 2026

ANALYSIS DESCRIPTION

Permanent gases were measured by thermal conductivity detection/gas chromatography (TCD/GC), ASTM D1946-90.

AtmAA Lab No.:	20896-20	20896-21	20896-22	20896-23
Sample I.D.:	Tank Farm 13	Tank Farm Canyon D	Flare Station Pre H2S	Flare Station Post H2S

Components	(Concentration in %,v)			
Nitrogen	76.85	77.04	25.39	21.74
Oxygen	21.42	20.88	6.07	5.02
Methane	<0.10	0.41	25.61	27.79
Carbon dioxide	1.65	1.32	35.54	39.00
Hydrogen	<0.10	0.18	2.44	2.68

The reported oxygen concentration includes any argon present in the sample. Calibration is based on a standard atmosphere containing 20.95% oxygen and 0.93% argon. The accuracy of permanent gas analysis by TCD/GC is +/- 2%, actual results are reported. Actual analysis results are reported on a "wet" basis.



Brian W. Fung
Laboratory Director

QUALITY ASSURANCE SUMMARY
(Repeat Analyses)

Project Location: Waste Connections
Date Received: March 30, 2026
Date Analyzed: March 30, 2026

Components	Sample ID	Repeat Analysis		Mean Conc.	% RPD
		Run #1	Run #2		
		<i>(Concentration in %,v)</i>			
Nitrogen	Zeeco Inlet	40.72	40.51	40.62	0.52
Oxygen	Zeeco Inlet	9.82	9.77	9.80	0.51
Methane	Zeeco Inlet	16.79	16.81	16.80	0.12
Carbon dioxide	Zeeco Inlet	29.84	29.79	29.82	0.17
Hydrogen	Zeeco Inlet	1.48	1.49	1.49	0.67

Seven Silco canister samples, laboratory numbers 20896-(17-23), were analyzed for permanent gases. Agreement between repeat analyses is a measure of precision and is shown above in the column "% RPD". The average % RPD from seven Silco canister samples is 0.40%.





LABORATORY ANALYSIS REPORT

Speciated Hydrocarbons Analysis in Silco Canister Samples

Report Date: April 6, 2026
Client: Montrose AQS
Project Location: Waste Connections
Project No.: PROJ-066231
Date Received: March 30, 2026
Date Analyzed: March 30, 2026
Laboratory Temp: 73.5 °F
Barometric Pressure: 29.97 inHg

ANALYSIS DESCRIPTION

Hydrocarbon speciation analysis was performed by flame ionization detection/gas chromatography (FID/GC), modified EPA-18. Methane was measured by thermal conductivity detection/gas chromatography (TCD/GC), ASTM D1946-90

AtmAA Lab No.:	20896-17	20896-18	20896-19
Sample ID:	Zeeco Inlet	Parnel Inlet	Hero Inlet

Component	(Concentration in ppmv, component)		
Methane	168000	157200	135300
Ethene	8.77	32.6	41.7
Acetylene	<0.30	<0.30	<0.30
Ethane	38.4	119	123

Non-methane hydrocarbons analysis by carbon number grouping

C3	160	386	392
C4	1140	3397	2784
C5	1211	2620	2289
C6	991	2393	2007
C7	290	872	605
C8	190	427	516
C9	196	548	440
C10	197	632	334
C11	41.9	110	57.1
C12	23.6	64.3	29.4
C13	8.51	32.7	8.04
C14	0.53	3.04	<0.03

	(Concentration in ppmvC)		
TNMHC	25273	65728	52878

TNMHC - total non-methane hydrocarbons as ppmvC.
Actual analysis results are reported on a "wet" basis.

Brian W. Fung
Laboratory Director



LABORATORY ANALYSIS REPORT

Speciated Hydrocarbons Analysis in Silco Canister Samples

Report Date: April 6, 2026
Client: Montrose AQS
Project Location: Waste Connections
Project No.: PROJ-066231
Date Received: March 30, 2026
Date Analyzed: March 30, 2026
Laboratory Temp: 73.5 °F
Barometric Pressure: 29.97 inHg

ANALYSIS DESCRIPTION

Hydrocarbon speciation analysis was performed by flame ionization detection/gas chromatography (FID/GC), modified EPA-18. Methane was measured by thermal conductivity detection/gas chromatography (TCD/GC), ASTM D1946-90

AtmAA Lab No.:	20896-20	20896-21	20896-22	20896-23
Sample ID:	Tank Farm 13	Tank Farm Canyon D	Flare Station Pre H2S	Flare Station Post H2S
<u>Component</u>	<i>(Concentration in ppmv, component)</i>			
Methane	350	4100	256100	277900
Ethene	0.37	0.47	8.84	4.50
Acetylene	<0.30	<0.30	<0.30	<0.20
Ethane	0.35	0.49	47.81	35.77
<u>Non-methane hydrocarbons analysis by carbon number grouping</u>				
C3	3.90	2.56	180	132
C4	202	61.2	1309	898
C5	217	119	1312	912
C6	100	42.8	1047	745
C7	33.1	7.6	343	196
C8	17.0	6.1	222	194
C9	19.8	5.57	259	192
C10	45	12.4	289	184
C11	15.6	6.32	60.8	34.8
C12	13.6	5.94	38.7	20.8
C13	6.64	4.70	16.28	8.82
C14	<0.06	<0.06	2.68	1.88

	<i>(Concentration in ppmvC)</i>			
TNMHC	3921	1585	29510	20354

TNMHC - total non-methane hydrocarbons as ppmvC.
Actual analysis results are reported on a "wet" basis.

Brian W. Fung
Laboratory Director

QUALITY ASSURANCE SUMMARY
(Repeat Analyses)

Project Location: Waste Connections
Date Received: March 30, 2026
Date Analyzed: March 30, 2026

Component	Sample ID	Repeat Analysis		Mean Conc.	% RPD
		Run #1	Run #2		
		<i>(Conc. in ppmv, component)</i>			
Methane	Tank Farm 13	348	352	350	1.2
Ethene	Tank Farm 13	0.39	0.35	0.37	9.6
Acetylene	Tank Farm 13	<0.30	<0.30	<0.30	---
Ethane	Tank Farm 13	0.33	0.37	0.35	9.4
<u>non-methane hydrocarbons analysis by carbon number grouping</u>					
C3	Tank Farm 13	3.87	3.92	3.90	1.2
C4	Tank Farm 13	204	201	202	1.5
C5	Tank Farm 13	219	215	217	1.7
C6	Tank Farm 13	99.4	100.4	99.9	0.96
C7	Tank Farm 13	32.9	33.4	33.1	1.5
C8	Tank Farm 13	16.9	17.2	17.0	1.8
C9	Tank Farm 13	19.8	19.8	19.8	0.20
C10	Tank Farm 13	44.7	45.0	44.8	0.69
C11	Tank Farm 13	15.6	15.6	15.6	0.26
C12	Tank Farm 13	13.3	13.8	13.6	3.9
C13	Tank Farm 13	6.48	6.80	6.64	4.9
C14	Tank Farm 13	<0.06	<0.06	<0.06	---
		<i>(Concentration in ppmvC)</i>			
TNMHC	Tank Farm 13	3924	3918	3921	0.15

Seven Silco canister samples, laboratory numbers 20896-(17-23), were analyzed for hydrocarbon speciation, EPA Method 18. Agreement between repeat analyses is a measure of precision and is shown above in the column "% RPD". The average % RPD for 15 repeat measurements from seven Silco canister samples is 2.6%.



Calculated values for Specific Volume, BTU, and F (factor)

Report Date: April 6, 2026
 Client: Montrose AQS
 Project Location: Waste Connections
 Date Received: March 30, 2026
 Date Analyzed: March 30, 2026
 AtmAA Lab #: 20896-17
 Sample ID: Zeeco Inlet

Specific volume, BTU, and F-factor are calculated using normalized laboratory analysis results for methane, carbon dioxide, nitrogen, oxygen, TNMHC, and sulfur compounds in equations that include gross/net heating and specific gas volume values taken from the GPA-2145 Midstream Standard. Heating value factor is a calculated according to ASTM 3588-98 (14.696 psia and 60°F). The F-factor is calculated according to the equation in EPA Method 19.

Component	Mole %	Wt %	C,H,O,N,S, Wt.%	
Methane	17.01	8.81	Carbon	18.79
Carbon dioxide	30.19	42.91	Hydrogen	2.41
Nitrogen	41.13	37.21	Oxygen	41.02
Oxygen	9.50	9.82	Nitrogen	37.21
Argon	0.42	0.54	Argon	0.54
Hydrogen	1.50	0.10	Sulfur	0.01
(CH ₂) _n	0.228	0.59		
Specific Volume		12.251		
BTU/ft ³ (Dry @60F, 14.696 psia)		186.9	(HHV)	168.3 (LHV)
BTU/ft ³ (Water Saturated @ 0.25636 psia)		183.7	(HHV)	165.4 (LHV)
BTU/lb (Dry @60F, 14.696 psia)		2290	(HHV)	2062 (LHV)
F _d (factor)		10426		
F _w (factor)		12459		
F _c (factor)		2634		
Compressibility Factor (@60F, 14.696 psia)		0.9983		
Wobbe Index		181.31		
Specific Gravity		1.0632		

Component	Specific volume reference values *
Methane	23.7 (ft ³ /lb)
Carbon dioxide	8.62
Nitrogen	13.5
Oxygen	11.9
Argon	9.52
Hydrogen	188.2

* reference, Rev. 2016, GPA-2145 Midstream Standard, Selected Hydrocarbons 60°F



Calculated values for Specific Volume, BTU, and F (factor)

Report Date: April 6, 2026
 Client: Montrose AQS
 Project Location: Waste Connections
 Date Received: March 30, 2026
 Date Analyzed: March 30, 2026
 AtmAA Lab #: 20896-18
 Sample ID: Parnel Inlet

Specific volume, BTU, and F-factor are calculated using normalized laboratory analysis results for methane, carbon dioxide, nitrogen, oxygen, TNMHC, and sulfur compounds in equations that include gross/net heating and specific gas volume values taken from the GPA-2145 Midstream Standard. Heating value factor is a calculated according to ASTM 3588-98 (14.696 psia and 60°F). The F-factor is calculated according to the equation in EPA Method 19.

Component	Mole %	Wt %	C,H,O,N,S, Wt.%	
Methane	16.14	7.77	Carbon	25.34
Carbon dioxide	47.26	62.59	Hydrogen	2.72
Nitrogen	24.61	20.74	Oxygen	50.89
Oxygen	5.57	5.37	Nitrogen	20.74
Argon	0.25	0.30	Argon	0.30
Hydrogen	4.95	0.30	Sulfur	0.02
(CH ₂) _n	1.195	2.92		
Specific Volume		11.406		
BTU/ft ³ (Dry @60F, 14.696 psia)		232.8	(HHV)	210.1 (LHV)
BTU/ft ³ (Water Saturated @ 0.25636 psia)		228.7	(HHV)	206.4 (LHV)
BTU/lb (Dry @60F, 14.696 psia)		2655	(HHV)	2396 (LHV)
F _d (factor)		10609		
F _w (factor)		12586		
F _c (factor)		3063		
Compressibility Factor (@60F, 14.696 psia)		0.9973		
Wobbe Index		217.5		
Specific Gravity		1.1461		

Component	Specific volume reference values *
Methane	23.7 (ft ³ /lb)
Carbon dioxide	8.62
Nitrogen	13.5
Oxygen	11.9
Argon	9.52
Hydrogen	188.2

* reference, Rev. 2016, GPA-2145 Midstream Standard, Selected Hydrocarbons 60°F



Calculated values for Specific Volume, BTU, and F (factor)

Report Date: April 6, 2026
 Client: Montrose AQS
 Project Location: Waste Connections
 Date Received: March 30, 2026
 Date Analyzed: March 30, 2026
 AtmAA Lab #: 20896-19
 Sample ID: Hero Inlet

Specific volume, BTU, and F-factor are calculated using normalized laboratory analysis results for methane, carbon dioxide, nitrogen, oxygen, TNMHC, and sulfur compounds in equations that include gross/net heating and specific gas volume values taken from the GPA-2145 Midstream Standard. Heating value factor is a calculated according to ASTM 3588-98 (14.696 psia and 60°F). The F-factor is calculated according to the equation in EPA Method 19.

Component	Mole %	Wt %	C,H,O,N,S, Wt.%	
Methane	14.07	6.75	Carbon	24.11
Carbon dioxide	47.43	62.58	Hydrogen	2.37
Nitrogen	27.35	22.96	Oxygen	50.29
Oxygen	4.98	4.78	Nitrogen	22.96
Argon	0.22	0.26	Argon	0.26
Hydrogen	4.94	0.30	Sulfur	0.01
(CH ₂) _n	1.001	2.37		
Specific Volume		11.363		
BTU/ft ³ (Dry @60F, 14.696 psia)		201.9	(HHV)	182.0 (LHV)
BTU/ft ³ (Water Saturated @ 0.25636 psia)		198.4	(HHV)	178.9 (LHV)
BTU/lb (Dry @60F, 14.696 psia)		2295	(HHV)	2069 (LHV)
F _d (factor)		11161		
F _w (factor)		13157		
F _c (factor)		3372		
Compressibility Factor (@60F, 14.696 psia)		0.9974		
Wobbe Index		188.4		
Specific Gravity		1.1487		

Component	Specific volume reference values *
Methane	23.7 (ft ³ /lb)
Carbon dioxide	8.62
Nitrogen	13.5
Oxygen	11.9
Argon	9.52
Hydrogen	188.2

* reference, Rev. 2016, GPA-2145 Midstream Standard, Selected Hydrocarbons 60°F



Calculated values for Specific Volume, BTU, and F (factor)

Report Date: April 6, 2026
 Client: Montrose AQS
 Project Location: Waste Connections
 Date Received: March 30, 2026
 Date Analyzed: March 30, 2026
 AtmAA Lab #: 20896-20
 Sample ID: Tank Farm 13

Specific volume, BTU, and F-factor are calculated using normalized laboratory analysis results for methane, carbon dioxide, nitrogen, oxygen, TNMHC, and sulfur compounds in equations that include gross/net heating and specific gas volume values taken from the GPA-2145 Midstream Standard. Heating value factor is a calculated according to ASTM 3588-98 (14.696 psia and 60°F). The F-factor is calculated according to the equation in EPA Method 19.

Component	Mole %	Wt %	C,H,O,N,S, Wt.%	
Methane	0.000	0.00	Carbon	1.00
Carbon dioxide	1.65	2.48	Hydrogen	0.06
Nitrogen	76.81	73.49	Oxygen	24.21
Oxygen	20.50	22.40	Nitrogen	73.49
Argon	0.91	1.24	Argon	1.24
Hydrogen	0.00	0.00	Sulfur	0.00
(CH ₂) _n	0.135	0.38		
Specific Volume		12.955		
BTU/ft ³ (Dry @60F, 14.696 psia)		6.218	(HHV)	5.756 (LHV)
BTU/ft ³ (Water Saturated @ 0.25636 psia)		6.109	(HHV)	5.656 (LHV)
BTU/lb (Dry @60F, 14.696 psia)		80.55	(HHV)	74.57 (LHV)
F _d (factor)		11300		
F _w (factor)		12815		
F _c (factor)		3975		
Compressibility Factor (@60F, 14.696 psia)		0.9996		
Wobbe Index		6.22		
Specific Gravity		0.9980		

Component	Specific volume reference values *
Methane	23.7 (ft ³ /lb)
Carbon dioxide	8.62
Nitrogen	13.5
Oxygen	11.9
Argon	9.52
Hydrogen	188.2

* reference, Rev. 2016, GPA-2145 Midstream Standard, Selected Hydrocarbons 60°F



Calculated values for Specific Volume, BTU, and F (factor)

Report Date: April 6, 2026
 Client: Montrose AQS
 Project Location: Waste Connections
 Date Received: March 30, 2026
 Date Analyzed: March 30, 2026
 AtmAA Lab #: 20896-21
 Sample ID: Tank Farm Canyon D

Specific volume, BTU, and F-factor are calculated using normalized laboratory analysis results for methane, carbon dioxide, nitrogen, oxygen, TNMHC, and sulfur compounds in equations that include gross/net heating and specific gas volume values taken from the GPA-2145 Midstream Standard. Heating value factor is a calculated according to ASTM 3588-98 (14.696 psia and 60°F). The F-factor is calculated according to the equation in EPA Method 19.

Component	Mole %	Wt %	C,H,O,N,S, Wt.%	
Methane	0.41	0.23	Carbon	0.78
Carbon dioxide	1.32	2.00	Hydrogen	0.08
Nitrogen	77.15	74.39	Oxygen	23.52
Oxygen	20.02	22.06	Nitrogen	74.39
Argon	0.89	1.22	Argon	1.22
Hydrogen	0.18	0.01	Sulfur	0.00
(CH ₂) _n	0.028	0.08		
Specific Volume		13.057		
BTU/ft3 (Dry @60F, 14.696 psia)		5.991	(HHV)	5.394 (LHV)
BTU/ft3 (Water Saturated @ 0.25636 psia)		5.886	(HHV)	5.299 (LHV)
BTU/lb (Dry @60F, 14.696 psia)		78.22	(HHV)	70.42 (LHV)
F _d (factor)		13919		
F _w (factor)		15938		
F _c (factor)		3207		
Compressibility Factor (@60F, 14.696 psia)		0.9996		
Wobbe Index		6.0		
Specific Gravity		0.9903		

Component	Specific volume reference values *
Methane	23.7 (ft ³ /lb)
Carbon dioxide	8.62
Nitrogen	13.5
Oxygen	11.9
Argon	9.52
Hydrogen	188.2

* reference, Rev. 2016, GPA-2145 Midstream Standard, Selected Hydrocarbons 60°F



Calculated values for Specific Volume, BTU, and F (factor)

Report Date: April 6, 2026
 Client: Montrose AQS
 Project Location: Waste Connections
 Date Received: March 30, 2026
 Date Analyzed: March 30, 2026
 AtmAA Lab #: 20896-22
 Sample ID: Flare Station Pre H2S

Specific volume, BTU, and F-factor are calculated using normalized laboratory analysis results for methane, carbon dioxide, nitrogen, oxygen, TNMHC, and sulfur compounds in equations that include gross/net heating and specific gas volume values taken from the GPA-2145 Midstream Standard. Heating value factor is a calculated according to ASTM 3588-98 (14.696 psia and 60°F). The F-factor is calculated according to the equation in EPA Method 19.

Component	Mole %	Wt %	C,H,O,N,S, Wt. %	
Methane	26.79	13.99	Carbon	26.27
Carbon dioxide	37.18	53.40	Hydrogen	3.90
Nitrogen	26.56	24.28	Oxygen	45.19
Oxygen	6.08	6.35	Nitrogen	24.28
Argon	0.27	0.35	Argon	0.35
Hydrogen	2.55	0.17	Sulfur	0.02
(CH ₂) _n	0.537	1.45		
Specific Volume		12.368		
BTU/ft3 (Dry @60F, 14.696 psia)		303.5	(HHV)	273.4 (LHV)
BTU/ft3 (Water Saturated @ 0.25636 psia)		298.2	(HHV)	268.7 (LHV)
BTU/lb (Dry @60F, 14.696 psia)		3754	(HHV)	3382 (LHV)
F _d (factor)		9860		
F _w (factor)		11867		
F _c (factor)		2246		
Compressibility Factor (@60F, 14.696 psia)		0.9977		
Wobbe Index		295.3		
Specific Gravity		1.0564		

Component	Specific volume reference values *
Methane	23.7 (ft ³ /lb)
Carbon dioxide	8.62
Nitrogen	13.5
Oxygen	11.9
Argon	9.52
Hydrogen	188.2

* reference, Rev. 2016, GPA-2145 Midstream Standard, Selected Hydrocarbons 60°F



Calculated values for Specific Volume, BTU, and F (factor)

Report Date: April 6, 2026
 Client: Montrose AQS
 Project Location: Waste Connections
 Date Received: March 30, 2026
 Date Analyzed: March 30, 2026
 AtmAA Lab #: 20896-23
 Sample ID: Flare Station Post H2S

Specific volume, BTU, and F-factor are calculated using normalized laboratory analysis results for methane, carbon dioxide, nitrogen, oxygen, TNMHC, and sulfur compounds in equations that include gross/net heating and specific gas volume values taken from the GPA-2145 Midstream Standard. Heating value factor is a calculated according to ASTM 3588-98 (14.696 psia and 60°F). The F-factor is calculated according to the equation in EPA Method 19.

Component	Mole %	Wt %	C,H,O,N,S, Wt. %	
Methane	28.77	14.99	Carbon	27.84
Carbon dioxide	40.37	57.84	Hydrogen	4.09
Nitrogen	22.50	20.52	Oxygen	47.25
Oxygen	4.98	5.18	Nitrogen	20.52
Argon	0.22	0.29	Argon	0.29
Hydrogen (CH ₂) _n	2.77 0.368	0.18 0.98	Sulfur	0.02
Specific Volume		12.339		
BTU/ft3 (Dry @60F, 14.696 psia)		316.4	(HHV)	284.8 (LHV)
BTU/ft3 (Water Saturated @ 0.25636 psia)		310.9	(HHV)	279.8 (LHV)
BTU/lb (Dry @60F, 14.696 psia)		3904	(HHV)	3514 (LHV)
F _d (factor)		9895		
F _w (factor)		11917		
F _c (factor)		2289		
Compressibility Factor (@60F, 14.696 psia)		0.9975		
Wobbe Index		307.4		
Specific Gravity		1.0590		

Component	Specific volume reference values *
Methane	23.7 (ft ³ /lb)
Carbon dioxide	8.62
Nitrogen	13.5
Oxygen	11.9
Argon	9.52
Hydrogen	188.2

* reference, Rev. 2016, GPA-2145 Midstream Standard, Selected Hydrocarbons 60°F





LABORATORY ANALYSIS REPORT

SCAQMD Rule 1150.1 Components Analysis in Silco Canister Samples

Report Date: April 6, 2026
Client: Montrose AQS
Project Name: Waste Connections Chiquita Leachate 1st Qtr
Project Location: Chiquita Leachate Landfill
Project No.: PROJ-066231
Date Received: March 30, 2026
Date Analyzed: March 30-31, 2026

AtmAA Lab No.:	20896-17	20896-18	20896-19	20896-20
Sample I.D.:	Zeeco Inlet	Parnel Inlet	Hero Inlet	Tank Farm 13

(Concentration in ppbv)

Components

Hydrogen sulfide	102300	158500	123500	<80
Benzene	79300	207000	146000	1510
Benzyl chloride	<17900	<17900	<17900	<50
Chlorobenzene	<20200	<20200	<20200	<50
Dichlorobenzenes*	<30900	<30900	<30900	78.9
1,1-dichloroethane	<22900	<22900	<22900	<60
1,2-dichloroethane	<22900	<22900	<22900	<60
1,1-dichloroethylene	<23400	<23400	<23400	<60
Dichloromethane	<53400	<53400	<53400	<125
1,2-dibromoethane	<12100	<12100	<12100	<30
Perchloroethylene	<13700	<13700	<13700	<30
Carbon tetrachloride	<29500	<29500	<29500	<70
Toluene	<24600	26600	<24600	245
1,1,1-trichloroethane	<17000	<17000	<17000	<40
Trichloroethene	<17300	<17300	<17300	<40
Chloroform	<19000	<19000	<19000	<45
Vinyl chloride	<18200	<18200	<18200	<45
m+p-xylenes	<21400	<21400	<21400	298
o-xylene	<21400	<21400	<21400	128

Toxic air contaminants (TAC) compounds were analyzed by GC/MS, EPA TO-15.

Hydrogen sulfide was analyzed by SCD/GC, SCAQMD 307.91.

* total amount containing meta, para, and ortho isomers



Brian W. Fung
Laboratory Director



LABORATORY ANALYSIS REPORT

SCAQMD Rule 1150.1 Components Analysis in Silco Canister Samples

Report Date: April 6, 2026
Client: Montrose AQS
Project Name: Waste Connections Chiquita Leachate 1st Qtr
Project Location: Chiquita Leachate Landfill
Project No.: PROJ-066231
Date Received: March 30, 2026
Date Analyzed: March 30-31, 2026

AtmAA Lab No.: 20896-21 20896-22 20896-23
Sample I.D.: Tank Farm Canyon B Flare Station Pre-H2S Flare Station Post-H2S
(Concentration in ppbv)

Components

Hydrogen sulfide	<80	165000	185500
Benzene	420	82200	92900
Benzyl chloride	<50	<17900	<17900
Chlorobenzene	<50	<20200	<20200
Dichlorobenzenes*	<70	<30900	<30900
1,1-dichloroethane	<60	<22900	<22900
1,2-dichloroethane	<60	<22900	<22900
1,1-dichloroethylene	<60	<23400	<23400
Dichloromethane	<125	<53400	<53400
1,2-dibromoethane	<30	<12100	<12100
Perchloroethylene	<30	<13700	<13700
Carbon tetrachloride	<70	<29500	<29500
Toluene	258	<24600	<24600
1,1,1-trichloroethane	<40	<17000	<17000
Trichloroethene	<40	<17300	<17300
Chloroform	<45	<19000	<19000
Vinyl chloride	<45	<18200	<18200
m+p-xylenes	104	<21400	<21400
o-xylene	43.8	<21400	<21400

Toxic air contaminants (TAC) compounds were analyzed by GC/MS, EPA TO-15.

Hydrogen sulfide was analyzed by SCD/GC, SCAQMD 307.91.

* total amount containing meta, para, and ortho isomers

Brian W. Fung
Laboratory Director

QUALITY ASSURANCE SUMMARY
(Repeat Analyses)

Project Name: Waste Connections Chiquita Leachate 1st Qtr
Date Received: March 30, 2026
Date Analyzed: March 30-31, 2026

Components	Sample ID	Repeat Analysis		Mean Conc.	% RPD
		Run #1	Run #2		
		(Concentration in ppbv)			
Hydrogen sulfide	Parnel Inlet	160000	157000	158500	1.9
Benzene	Parnel Inlet	203000	211000	207000	3.9
Benzyl chloride	Parnel Inlet	<17900	<17900	---	---
Chlorobenzene	Parnel Inlet	<20200	<20200	---	---
Dichlorobenzenes	Parnel Inlet	<30900	<30900	---	---
1,1-dichloroethane	Parnel Inlet	<22900	<22900	---	---
1,2-dichloroethane	Parnel Inlet	<22900	<22900	---	---
1,1-dichloroethylene	Parnel Inlet	<23400	<23400	---	---
Dichloromethane	Parnel Inlet	<53400	<53400	---	---
1,2-dibromoethane	Parnel Inlet	<12100	<12100	---	---
Perchloroethylene	Parnel Inlet	<13700	<13700	---	---
Carbon tetrachloride	Parnel Inlet	<29500	<29500	---	---
Toluene	Parnel Inlet	26100	27100	26600	3.8
1,1,1-trichloroethane	Parnel Inlet	<17000	<17000	---	---
Trichloroethene	Parnel Inlet	<17300	<17300	---	---
Chloroform	Parnel Inlet	<19000	<19000	---	---
Vinyl chloride	Parnel Inlet	<18200	<18200	---	---
m+p-xylenes	Parnel Inlet	<21400	<21400	---	---
o-xylene	Parnel Inlet	<21400	<21400	---	---

Seven Silco canister samples, laboratory numbers 20896-(17-23), were analyzed for SCAQMD Rule 1150.1 components. Agreement between repeat analyses is a measure of precision and is shown above in the column "% RPD". The average % RPD from seven Silco canister samples is 3.2%.





LABORATORY ANALYSIS REPORT

Hydrogen Sulfide and Reduced Sulfur Compounds
Analysis in Silco Canister Sample by SCAQMD Method 307.91

Report Date: April 6, 2026
Client: Montrose AQS
Project Name: Waste Connections Chiquita Leachate 1st Qtr
Project Location: Chiquita Leachate Landfill
Project No.: PROJ-066231
Date Received: March 30, 2026
Date Analyzed: March 30, 2026

ANALYSIS DESCRIPTION

Total sulfur analysis measured by gas chromatography with sulfur chemiluminescence detector (SCD), SCAQMD 307.91.

AtmAA Lab No.:	20896-17	20896-18	20896-19	20896-20
Sample I.D.:	Zeeco Inlet	Parnel Inlet	Hero Inlet	Tank Farm 13
Components	<i>(Concentration in ppmv)</i>			
Hydrogen sulfide	102	159	124	<0.08
Carbonyl sulfide	<0.50	<2.00	<2.00	<0.08
Methyl mercaptan	108	344	325	0.34
Ethyl mercaptan	1.68	3.72	3.62	<0.08
Dimethyl sulfide	334	975	924	14.67
Carbon disulfide	<0.50	<2.00	<2.00	<0.08
i-Propyl mercaptan	1.33	2.54	2.32	<0.08
t-Butyl mercaptan	<0.50	<2.00	<2.00	<0.08
n-Propyl mercaptan	4.69	10.8	10.8	0.12
s-Butyl mercaptan	4.78	11.2	10.7	<0.08
i-Butyl mercaptan	<0.50	<2.00	<2.00	0.34
Dimethyl disulfide	1.50	7.52	5.76	<0.08
Tetrahydrothiophene	1.90	7.34	6.81	<0.08
Unidentified sulfurs	11.2	29.5	21.4	0.10

(Concentration in ppmv, as H₂S)

Total Sulfur	572.32	1557.10	1439.64	15.56
--------------	--------	---------	---------	-------



Brian W. Fung
Laboratory Director



LABORATORY ANALYSIS REPORT

Hydrogen Sulfide and Reduced Sulfur Compounds
Analysis in Silco Canister Sample by SCAQMD Method 307.91

Report Date: April 6, 2026
Client: Montrose AQS
Project Name: Waste Connections Chiquita Leachate 1st Qtr
Project Location: Chiquita Leachate Landfill
Project No.: PROJ-066231
Date Received: March 30, 2026
Date Analyzed: March 30, 2026

ANALYSIS DESCRIPTION

Total sulfur analysis measured by gas chromatography with sulfur chemiluminescence detector (SCD), SCAQMD 307.91.

AtmAA Lab No.:	20896-21	20896-22	20896-23
Sample I.D.:	Tank Farm Canyon B	Flare Station Pre-H2S	Flare Station Post-H2S
Components	(Concentration in ppmv)		
Hydrogen sulfide	0.13	165	186
Carbonyl sulfide	<0.08	<0.80	<0.80
Methyl mercaptan	0.79	105	108
Ethyl mercaptan	<0.08	1.26	1.37
Dimethyl sulfide	5.19	363	351
Carbon disulfide	<0.08	<0.80	<0.80
i-Propyl mercaptan	<0.08	1.91	1.88
t-Butyl mercaptan	<0.08	<0.80	<0.80
n-Propyl mercaptan	<0.08	3.88	4.03
s-Butyl mercaptan	<0.08	4.87	4.85
i-Butyl mercaptan	<0.08	<0.80	<0.80
Dimethyl disulfide	<0.08	2.78	2.51
Tetrahydrothiophene	<0.08	2.54	2.32
Unidentified sulfurs	<0.08	9.88	9.77

(Concentration in ppmv, as H₂S)

Total Sulfur	6.11	662.39	672.72
--------------	------	--------	--------

Brian W. Fung
Laboratory Director

QUALITY ASSURANCE SUMMARY
(Repeat Analyses)

Project Name: Waste Connections Chiquita Leachate 1st Qtr
Date Received: March 30, 2026
Date Analyzed: March 30, 2026

Components	Sample ID	Repeat Analysis		Mean Conc.	% RPD
		Run #1	Run #2		
<i>(Concentration in ppmv)</i>					
Hydrogen sulfide	Zeeco Inlet	100	105	102	5.3
	Parnel Inlet	160	157	159	1.9
	Hero Inlet	127	120	124	5.7
	Tank Farm 13	<0.08	<0.08	---	---
	Tank Farm Canyon B	0.13	0.13	0.13	0.00
	Flare Station Pre-H2S	156	174	165	11
	Flare Station Post-H2S	188	183	186	2.7
Carbonyl sulfide	Zeeco Inlet	<0.50	<0.50	---	---
	Parnel Inlet	<2.00	<2.00	---	---
	Hero Inlet	<2.00	<2.00	---	---
	Tank Farm 13	<0.08	<0.08	---	---
	Tank Farm Canyon B	<0.08	<0.08	---	---
	Flare Station Pre-H2S	<0.80	<0.80	---	---
	Flare Station Post-H2S	<0.80	<0.80	---	---
Methyl mercaptan	Zeeco Inlet	105	110	108	4.7
	Parnel Inlet	341	346	344	1.5
	Hero Inlet	330	320	325	3.1
	Tank Farm 13	0.34	0.34	0.34	0.00
	Tank Farm Canyon B	0.79	0.78	0.79	1.3
	Flare Station Pre-H2S	106	104	105	1.9
	Flare Station Post-H2S	109	106	108	2.8
Ethyl mercaptan	Zeeco Inlet	1.63	1.72	1.68	5.4
	Parnel Inlet	3.68	3.75	3.72	1.9
	Hero Inlet	3.62	3.62	3.62	0.00
	Tank Farm 13	<0.08	<0.08	---	---
	Tank Farm Canyon B	<0.08	<0.08	---	---
	Flare Station Pre-H2S	1.23	1.29	1.3	4.8
	Flare Station Post-H2S	1.43	1.31	1.37	8.8
Dimethyl sulfide	Zeeco Inlet	328	340	334	3.6
	Parnel Inlet	961	989	975	2.9
	Hero Inlet	932	916	924	1.7
	Tank Farm 13	14.5	14.9	14.7	2.5
	Tank Farm Canyon B	5.22	5.16	5.19	1.2
	Flare Station Pre-H2S	360	365	363	1.4
	Flare Station Post-H2S	356	345	351	3.1
Carbon disulfide	Zeeco Inlet	<0.50	<0.50	---	---
	Parnel Inlet	<2.00	<2.00	---	---
	Hero Inlet	<2.00	<2.00	---	---
	Tank Farm 13	<0.08	<0.08	---	---
	Tank Farm Canyon B	<0.08	<0.08	---	---
	Flare Station Pre-H2S	<0.80	<0.80	---	---
	Flare Station Post-H2S	<0.80	<0.80	---	---



QUALITY ASSURANCE SUMMARY
(Repeat Analyses)
(continued)

Components	Sample ID	Repeat Analysis		Mean Conc.	% RPD
		Run #1	Run #2		
<i>(Concentration in ppmv)</i>					
i-Propyl mercaptan	Zeeco Inlet	1.32	1.33	1.33	0.75
	Parnel Inlet	2.42	2.65	2.54	9.1
	Hero Inlet	2.20	2.43	2.32	10
	Tank Farm 13	<0.08	<0.08	---	---
	Tank Farm Canyon B	<0.08	<0.08	---	---
	Flare Station Pre-H2S	1.88	1.94	1.91	3.1
	Flare Station Post-H2S	1.92	1.84	1.88	4.3
t-Butyl mercaptan	Zeeco Inlet	<0.50	<0.50	---	---
	Parnel Inlet	<2.00	<2.00	---	---
	Hero Inlet	<2.00	<2.00	---	---
	Tank Farm 13	<0.08	<0.08	---	---
	Tank Farm Canyon B	<0.08	<0.08	---	---
	Flare Station Pre-H2S	<0.80	<0.80	---	---
	Flare Station Post-H2S	<0.80	<0.80	---	---
n-Propyl mercaptan	Zeeco Inlet	4.56	4.82	4.69	5.5
	Parnel Inlet	10.7	10.9	10.8	1.9
	Hero Inlet	10.7	10.8	10.8	0.93
	Tank Farm 13	0.12	0.12	0.12	0.00
	Tank Farm Canyon B	<0.08	<0.08	---	---
	Flare Station Pre-H2S	3.87	3.89	3.88	0.52
	Flare Station Post-H2S	4.11	3.95	4.03	4.0
s-Butyl mercaptan	Zeeco Inlet	4.67	4.89	4.78	4.6
	Parnel Inlet	11.0	11.4	11.2	3.6
	Hero Inlet	11.0	10.4	10.7	5.6
	Tank Farm 13	<0.08	<0.08	---	---
	Tank Farm Canyon B	<0.08	<0.08	---	---
	Flare Station Pre-H2S	4.82	4.92	4.87	2.1
	Flare Station Post-H2S	4.88	4.82	4.85	1.2
i-Butyl mercaptan	Zeeco Inlet	<0.50	<0.50	---	---
	Parnel Inlet	<2.00	<2.00	---	---
	Hero Inlet	<2.00	<2.00	---	---
	Tank Farm 13	0.33	0.34	0.34	3.0
	Tank Farm Canyon B	<0.08	<0.08	---	---
	Flare Station Pre-H2S	<0.80	<0.80	---	---
	Flare Station Post-H2S	<0.80	<0.80	---	---
Dimethyl disulfide	Zeeco Inlet	1.52	1.48	1.50	2.7
	Parnel Inlet	7.60	7.43	7.52	2.3
	Hero Inlet	5.95	5.56	5.76	6.8
	Tank Farm 13	<0.08	<0.08	---	---
	Tank Farm Canyon B	<0.08	<0.08	---	---
	Flare Station Pre-H2S	2.78	2.77	2.8	0.36
	Flare Station Post-H2S	2.57	2.44	2.51	5.2



QUALITY ASSURANCE SUMMARY
 (Repeat Analyses)
 (continued)

Components	Sample ID	Repeat Analysis		Mean Conc.	% RPD
		Run #1	Run #2		
		(Concentration in ppmv)			
Tetrahydrothiophene	Zeeco Inlet	1.84	1.95	1.90	5.8
	Parnel Inlet	6.94	7.73	7.34	11
	Hero Inlet	6.78	6.84	6.81	0.88
	Tank Farm 13	<0.08	<0.08	---	---
	Tank Farm Canyon B	<0.08	<0.08	---	---
	Flare Station Pre-H2S	2.51	2.57	2.54	2.4
	Flare Station Post-H2S	2.34	2.29	2.32	2.2
Unidentified sulfurs	Zeeco Inlet	11.0	11.3	11.2	2.7
	Parnel Inlet	28.8	30.2	29.5	4.6
	Hero Inlet	22.3	20.6	21.4	7.8
	Tank Farm 13	0.11	0.09	0.10	16
	Tank Farm Canyon B	<0.08	<0.08	---	---
	Flare Station Pre-H2S	9.73	10.0	9.88	3.1
	Flare Station Post-H2S	9.90	9.63	9.77	2.8

Seven Silco canister samples, laboratory numbers 20896-(17-23), were analyzed for total sulfur compounds. Agreement between repeat analyses is a measure of precision and is shown above in the column "% RPD". The average % RPD from seven Silco canister samples is 3.7%.



CHAIN OF CUSTODY RECORD

Client/Project Name: WASTE CONNECTIONS
 CHIQUITA LEACHATE ISOTR
 Project Number: PDS-066231
 Project Location: CHIQUITA LEACHATE LANDFILL
 Purchase Order Number:

Turnaround Times: Standard 10 day
 Expedited: 24hr / 48hr / 72hr / 5 day
 Sampler: (Signature)
 Type of Sample Canister ID

Client Sample Identification	Type of Sample Canister ID	AtmAA Lab Number	Sampling Date	Sampling Time	Special Remarks
ZEEBO INLET	0554	20896-17	3/30/26	0730	ASPM 1945/3588 TICKED GASTS TO-15 Rule 158.1 STANDARD 307-91
PARNEL INLET	240026	-16		0730	
HEAD INLET	0550	-19		0810	
TANK FARM B3	0576	-20		0845	
TANK FARM CANYON	53503	-21		0845	
FLARE STATION FACE H2S	226011	-22		0920	
FLARE STATION POST H2S	0571	-23		0920	

Relinquished by: (Signature) [Signature] Date: 3/30/26 Time: 11:11
 Received by: (Signature) [Signature] Date: 3/30/26 Time: 11:11
 Relinquished by: (Signature) [Signature] Date: [] Time: []
 Received by: (Signature) [Signature] Date: [] Time: []
 Relinquished by: (Signature) [Signature] Date: [] Time: []
 Received for Laboratory by: (Signature) [Signature] Date: 3/30/26 Time: 11:11
 Analytical Laboratory

Company Info:
 Company: MONTROSE ACS
 Street Address: 1631 E. ST. ANDREW P
 City/State/Zip: SANTA ANA
 Telephone No.: 626-617-6313
 Email Address: pjanjanc@montrose-env.com
 Company: AtmAA Inc.
 Street Address: 23917 Craftsman Rd.
 City/State/Zip: Calabasas, CA 91302
 Project Manager: []
 Email Address: info@atmaa.com

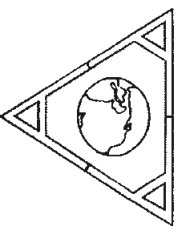

Appendix A.4 Quality Assurance Data

Barometric Pressure Determination

Date: 03/30/26

Time: 7:00

Data By: SJ, AD, JI

Reference: <https://forecast.weather.gov/MapClick.php?lat=33.6873&lon=-118.66712>
 Lat: 34.42972°N Lon: 118.66712°W Elev: 1278.0ft.

Reference Barometer ID	DEL VALLE (DLVC1)
Reference Barometer Location	
Reference Barometer Other Info.	
Reference Barometer Indication, correctedd to sea level	29.91
Reference Barometer Reference Elevation	1278
Reference Barometer Actual Pressure	28.63
Test Barometer Location/Site	Chiquita Canyon
Location/Site Elevation	997
Location/Site Barometric Pressure	28.91
Sampling Location Height (above/below site elevation)	1
Sampling Location Barometric Pressure	28.91



DIGITAL TEMPERATURE READOUT CALIBRATION

Digital Temperature Readout ID: PTC-43
 Readout Description: Handheld
 Date: 1/2/2026
 Performed By: PR/RMO

Calibrated Thermocouple ID: TC-Cal
 T1 Reference Thermometer ID: 2736
 T2 Reference Thermometer ID: 2786
 T3 Reference Thermometer ID: 0425-3218

T/C I.D.	Readout I.D.	T/C - Readout °F				Reference Thermometer °F				Difference		
		Reading 1	Reading 2	Reading 3	Average	Reading 1	Reading 2	Reading 3	Average	°F	%, (°R)	
TC-Cal												
T3 (~ 370 F)	PTC-43	369	369	369	369	370	370	370	370	1.0	0.1%	Pass
T2 (~212 F)	PTC-43	209	209	209	209	212	212	212	212	3.0	0.4%	Pass
T1 (~ 32 F)	PTC-43	28	28	28	28	32	32	32	32	4.0	0.8%	Pass

- 1) Difference % (°R) = Difference (°F) / (Average Tref + 460)
- 2) Pass if all Differences are less than 1.5% (°R)

Thermocouple Source Readings

T/C Source S/N	T/C - Readout °F				T/C Source °F				Difference			
	Reading 1	Reading 2	Reading 3	Average	Reading 1	Reading 2	Reading 3	Average	°F	%, (°R)		
T4 (~650 F)	129462	651	651	651	651	650	650	650	650	1.0	0.1%	Pass
T3 (~370 F)	129462	369	369	369	369	370	370	370	370	1.0	0.1%	Pass
T2 (~212 F)	129462	212	212	212	212	212	212	212	212	0.0	0.0%	Pass
T1 (~32 F)	129462	31	31	31	31	32	32	32	32	1.0	0.2%	Pass

- 1) Difference % (°R) = Difference (°F) / (Average Tref + 460)
- 2) Pass if all Differences are less than 1.5% (°R)



THERMOCOUPLE CALIBRATION

Thermocouple ID: 30
 Date: 1/2/2026
 Performed By: PR/RMO

Calibrated Digital Temperature Readout ID: PTC-93
 T1 Reference Thermometer ID: 2736
 T2 Reference Thermometer ID: 2786
 T3 Reference Thermometer ID: 0425-3218

T/C I.D. 30	Readout I.D.	T/C - Readout °F				Reference Thermometer °F				Difference		
		Reading 1	Reading 2	Reading 3	Average	Reading 1	Reading 2	Reading 3	Average	°F	%, (°R)	
T3 (~ 370 F)	PTC-93	369	369	369	369	370	370	370	370	1.0	0.1%	Pass
T2 (~ 212 F)	PTC-93	217	217	217	217	212	212	212	212	5.0	0.7%	Pass
T1 (~ 32 F)	PTC-93	37	37	37	37	32	32	32	32	5.0	1.0%	Pass

- 1) Difference % (°R) = Difference (°F) / (Average Tref + 460)
- 2) Pass if all Differences are less than 1.5% (°R)



THERMOCOUPLE CALIBRATION

Thermocouple ID: TC-WB
 Date: 1/2/2026
 Performed By: PR/RMO

Calibrated Digital Temperature Readout ID: PTC-93
 T1 Reference Thermometer ID: 2736
 T2 Reference Thermometer ID: 2786
 T3 Reference Thermometer ID: 0425-3218

T/C I.D. TC-WB	Readout I.D.	T/C - Readout °F				Reference Thermometer °F				Difference		
		Reading 1	Reading 2	Reading 3	Average	Reading 1	Reading 2	Reading 3	Average	°F	%, (°R)	
T3 (~ 370 F)	PTC-93	373	373	373	373	370	370	370	370	3.0	0.4%	Pass
T2 (~ 212 F)	PTC-93	220	220	220	220	212	212	212	212	8.0	1.2%	Pass
T1 (~ 32 F)	PTC-93	39	39	39	39	32	32	32	32	7.0	1.4%	Pass

- 1) Difference % (°R) = Difference (°F) / (Average Tref + 460)
- 2) Pass if all Differences are less than 1.5% (°R)

S Type Pitot Tube Dimensional Calibration Record

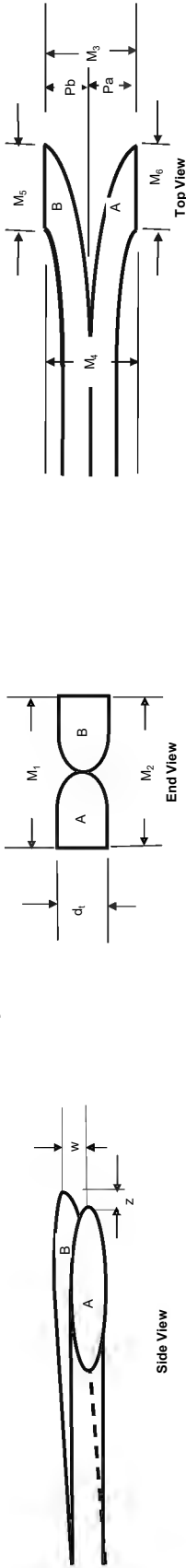

Pitot ID	Acceptability Criteria		Date	Calibrated By	Side View, Impact openings Properly aligned, $z < 1/8"$	Side View, Impact openings Properly aligned, $w < 1/32"$	Yes	"3/16" < Dt < 3/8"	Tubing Diameter, dt	M1	M2	M3	M4	M5	M6	n/a	10 degrees Average Face Opening Plane Angle, offset from perpendicular to transverse axis	5 degrees Average Face Opening Plane Angle from parallel to Longitudinal Axis	1.05 Dt < P < 1.5 Dt	Ratio of P/Dt	Status	
	1/2/26	JL/RC																				Y
030	1/2/26	JL/RC	Y	Y	Y	0.520	0.530	0.520	0.530	0.530	0.300	0.300	0.300	0.300	0.300	-1.3	-1.0	1.2	Pass			

Notes: Reference "A Type-S Pitot Tube Calibration Study", Robert F. Volaro, October 15, 1975
 If tube is not visibly deformed it is assumed that $P_a = P_b = .5 \times \text{avg. of } M1 \text{ \& } M2$, and that average face opening plane angles represent individual angles to tube axis

DIFFERENTIAL PRESSURE CALIBRATION

Semi-annual

Reference Device ID: Microrector
 Reference Serial Number: S270
 Calibrated By: K. Thomas

Display ID: ADM 9
 Description: Air Data Multimeter (ADM 850)
 Serial Number: M14140
 Calibration Date: 1/2/2026

Calibration Range		Run 1		Individual Run Results		
Scale:	inches H ₂ O	Measured Value (inches W.C.)	Reference Value (inches W.C.)	Absolute Value	% Difference	Pass/ Fail
Target 20%	0.010	0.010	0.010	0.0000	0.00%	Pass
Target 40%	0.020	0.020	0.020	0.0000	0.00%	Pass
Target 60%	0.030	0.031	0.030	0.0010	3.33%	Pass
Target 80%	0.040	0.040	0.040	0.0000	0.00%	Pass
Target 100%	0.050	0.050	0.050	0.0000	0.00%	Pass

Calibration Range		Run 2		Individual Run Results		
Scale:	inches H ₂ O	Measured Value (inches W.C.)	Reference Value (inches W.C.)	Absolute Value	% Difference	Pass/ Fail
Target 20%	0.010	0.010	0.010	0.0000	0.00%	Pass
Target 40%	0.020	0.020	0.020	0.0000	0.00%	Pass
Target 60%	0.030	0.030	0.030	0.0000	0.00%	Pass
Target 80%	0.040	0.041	0.040	0.0010	2.50%	Pass
Target 100%	0.050	0.051	0.050	0.0010	2.00%	Pass

Calibration Range		Run 3		Individual Run Results		
Scale:	inches H ₂ O	Measured Value (inches W.C.)	Reference Value (inches W.C.)	Absolute Value	% Difference	Pass/ Fail
Target 20%	0.010	0.010	0.010	0.0000	0.00%	Pass
Target 40%	0.020	0.020	0.020	0.0000	0.00%	Pass
Target 60%	0.030	0.030	0.030	0.0000	0.00%	Pass
Target 80%	0.040	0.040	0.040	0.0000	0.00%	Pass
Target 100%	0.050	0.050	0.050	0.0000	0.00%	Pass

Average results for three runs

% Difference	Pass/Fail
0.52%	Pass

Criteria: Each individual measured value within + or - 5.0% of reference value.
 Percent difference of three run average within 5.0 %.



DIFFERENTIAL PRESSURE CALIBRATION

Semi-annual

Reference Device ID: Microrector
 Reference Serial Number: S270
 Calibrated By: K. Thomas

Display ID: ADM 9
 Description: Air Data Multimeter (ADM 850)
 Serial Number: M14140
 Calibration Date: 1/2/2026

Calibration Range		Run 1		Individual Run Results		
Scale:	inches H ₂ O	Measured Value (inches W.C.)	Reference Value (inches W.C.)	Absolute Value	% Difference	Pass/ Fail
Target 20%	0.020	0.020	0.020	0.0000	0.00%	Pass
Target 40%	0.040	0.041	0.040	0.0010	2.50%	Pass
Target 60%	0.060	0.062	0.060	0.0020	3.33%	Pass
Target 80%	0.080	0.083	0.080	0.0030	3.75%	Pass
Target 100%	0.100	0.099	0.100	0.0010	1.00%	Pass

Calibration Range		Run 2		Individual Run Results		
Scale:	inches H ₂ O	Measured Value (inches W.C.)	Reference Value (inches W.C.)	Absolute Value	% Difference	Pass/ Fail
Target 20%	0.020	0.020	0.020	0.0000	0.00%	Pass
Target 40%	0.040	0.041	0.040	0.0010	2.50%	Pass
Target 60%	0.060	0.062	0.060	0.0020	3.33%	Pass
Target 80%	0.080	0.080	0.080	0.0000	0.00%	Pass
Target 100%	0.100	0.100	0.100	0.0000	0.00%	Pass

Calibration Range		Run 3		Individual Run Results		
Scale:	inches H ₂ O	Measured Value (inches W.C.)	Reference Value (inches W.C.)	Absolute Value	% Difference	Pass/ Fail
Target 20%	0.020	0.020	0.020	0.0000	0.00%	Pass
Target 40%	0.040	0.041	0.040	0.0010	2.50%	Pass
Target 60%	0.060	0.060	0.060	0.0000	0.00%	Pass
Target 80%	0.080	0.082	0.080	0.0020	2.50%	Pass
Target 100%	0.100	0.100	0.100	0.0000	0.00%	Pass

Average results for three runs

% Difference	Pass/Fail
1.43%	Pass

Criteria: Each individual measured value within + or - 5.0% of reference value.
 Percent difference of three run average within 5.0 %.



DIFFERENTIAL PRESSURE CALIBRATION

Semi-annual

Display ID: ADM 9
 Description: Air Data Multimeter (ADM 850)
 Serial Number: M14140
 Calibration Date: 1/2/2026

Reference Device ID: Microrector
 Reference Serial Number: S270
 Calibrated By: K. Thomas

Calibration Range		Run 1		Individual Run Results		
Scale:	inches H ₂ O	Measured Value (inches W.C.)	Reference Value (inches W.C.)	Absolute Value	% Difference	Pass/ Fail
Target 20%	0.200	0.200	0.200	0.0000	0.00%	Pass
Target 40%	0.400	0.405	0.400	0.0050	1.25%	Pass
Target 60%	0.600	0.610	0.600	0.0100	1.67%	Pass
Target 80%	0.800	0.790	0.800	0.0100	1.25%	Pass
Target 100%	1.000	1.000	1.000	0.0000	0.00%	Pass

Calibration Range		Run 2		Individual Run Results		
Scale:	inches H ₂ O	Measured Value (inches W.C.)	Reference Value (inches W.C.)	Absolute Value	% Difference	Pass/ Fail
Target 20%	0.200	0.210	0.200	0.0100	5.00%	Pass
Target 40%	0.400	0.415	0.400	0.0150	3.75%	Pass
Target 60%	0.600	0.595	0.600	0.0050	0.83%	Pass
Target 80%	0.800	0.810	0.800	0.0100	1.25%	Pass
Target 100%	1.000	1.000	1.000	0.0000	0.00%	Pass

Calibration Range		Run 3		Individual Run Results		
Scale:	inches H ₂ O	Measured Value (inches W.C.)	Reference Value (inches W.C.)	Absolute Value	% Difference	Pass/ Fail
Target 20%	0.200	0.200	0.200	0.0000	0.00%	Pass
Target 40%	0.400	0.405	0.400	0.0050	1.25%	Pass
Target 60%	0.600	0.600	0.600	0.0000	0.00%	Pass
Target 80%	0.800	0.805	0.800	0.0050	0.63%	Pass
Target 100%	1.000	1.000	1.000	0.0000	0.00%	Pass

Average results for three runs

% Difference	1.13%	Pass/Fail	Pass
--------------	-------	-----------	------

Criteria: Each individual measured value within + or - 5.0% of reference value.
 Percent difference of three run average within 5.0 %.



DIFFERENTIAL PRESSURE CALIBRATION

Semi-annual

Reference Device ID: Dwyer 0 - 10" Manometer
 Reference Serial Number: CC-2
 Calibrated By: K. Thomas

Display ID: ADM 9
 Description: Air Data Multimeter (ADM 850)
 Serial Number: M14140
 Calibration Date: 1/2/2026

Calibration Range		Run 1		Individual Run Results		
Scale: 0 - 10.000 inches H ₂ O		Measured Value (inches W.C.)	Reference Value (inches W.C.)	Absolute Value	% Difference	Pass/ Fail
Target 20%	2.000	2.000	2.000	0.0000	0.00%	Pass
Target 40%	4.000	4.060	4.000	0.0600	1.50%	Pass
Target 60%	6.000	6.075	6.000	0.0750	1.25%	Pass
Target 80%	8.000	8.000	8.000	0.0000	0.00%	Pass
Target 100%	10.000	9.995	10.000	0.0050	0.05%	Pass

Calibration Range		Run 2		Individual Run Results		
Scale: 0 - 10.000 inches H ₂ O		Measured Value (inches W.C.)	Reference Value (inches W.C.)	Absolute Value	% Difference	Pass/ Fail
Target 20%	2.000	2.000	2.000	0.0000	0.00%	Pass
Target 40%	4.000	4.010	4.000	0.0100	0.25%	Pass
Target 60%	6.000	6.060	6.000	0.0600	1.00%	Pass
Target 80%	8.000	8.000	8.000	0.0000	0.00%	Pass
Target 100%	10.000	10.000	10.000	0.0000	0.00%	Pass

Calibration Range		Run 3		Individual Run Results		
Scale: 0 - 10.000 inches H ₂ O		Measured Value (inches W.C.)	Reference Value (inches W.C.)	Absolute Value	% Difference	Pass/ Fail
Target 20%	2.000	2.000	2.000	0.0000	0.00%	Pass
Target 40%	4.000	4.010	4.000	0.0100	0.25%	Pass
Target 60%	6.000	6.005	6.000	0.0050	0.08%	Pass
Target 80%	8.000	8.015	8.000	0.0150	0.19%	Pass
Target 100%	10.000	10.000	10.000	0.0000	0.00%	Pass

Average results for three runs

% Difference	Pass/Fail
0.30%	Pass

Criteria: Each individual measured value within + or - 5.0% of reference value.
 Percent difference of three run average within 5.0 %.



APPENDIX B GENERAL EMISSIONS CALCULATIONS

GENERAL EMISSIONS CALCULATIONS

I. Stack Gas Velocity

A. Stack gas molecular weight, lb/lb-mole

$$MW_{dry} = 0.44 * \% CO_2 + 0.32 * \% O_2 + 0.28 * \% N_2$$

$$MW_{wet} = MW_{dry} * (1 - B_{wo}) + 18 * B_{wo}$$

B. Absolute stack pressure, iwg

$$P_s = P_{bar} + \frac{P_{sg}}{13.6}$$

C. Stack gas velocity, ft/sec

$$V_s = 2.9 * C_p * \sqrt{\Delta P} * \sqrt{T_s} * \sqrt{\frac{29.92 * 28.95}{P_s * MW_{wet}}}$$

II. Moisture

A. Sample gas volume, dscf

$$V_{mstd} = 0.03342 * V_m * \left(P_{bar} + \frac{\Delta H}{13.6} \right) * \frac{T_{ref}}{T_m} * Y_d$$

B. Water vapor volume, scf

$$V_{wstd} = 0.0472 * V_{ic} * \frac{T_{ref}}{528^{\circ}R}$$

C. Moisture content, dimensionless

$$B_{wo} = \frac{V_{wstd}}{(V_{mstd} + V_{wstd})}$$

III. Stack Gas Volumetric Flow Rate

A. Actual stack gas volumetric flow rate, wacfm

$$Q = V_s * A_s * 60$$

B. Standard stack gas flow rate, dscfm

$$Q_{sd} = Q * (1 - B_{wo}) * \frac{T_{ref}}{T_s} * \frac{P_s}{29.92}$$

SCS Engineers – Chiquita Canyon Landfill
 2026 1st Quarter Leachate and Condensate Vapor Sampling

Nomenclature:

A_s	=	stack area, ft ²
B_{wo}	=	flue gas moisture content, dimensionless
$C_{12\%CO_2}$	=	particulate grain loading, gr/dscf corrected to 12% CO ₂
C	=	particulate grain loading, gr/dscf
C_p	=	pitot calibration factor, dimensionless
D_n	=	nozzle diameter, inches
F	=	fuel F-Factor, dscf/MMBtu @ 0% O ₂
H	=	orifice differential pressure, iwg
I	=	% isokinetics
M_n	=	mass of collected particulate, mg
M_i	=	mass emission rate of specie i, lb/hr
MW	=	molecular weight of flue gas, lb/lb-mole
M_{wi}	=	molecular weight of specie i:
		SO ₂ : 64
		NO _x : 46
		CO: 28
		HC: 16
t	=	sample time, minutes
ΔP	=	average velocity head, iwg = $(\sqrt{\Delta P})^2$
P_{bar}	=	barometric pressure, inches Hg
P_s	=	stack absolute pressure, inches Hg
P_{sg}	=	stack static pressure, iwg
Q	=	wet stack flow rate at actual conditions, wacfm
Q_{sd}	=	dry standard stack flow rate, dscfm
SV	=	specific molar volume of an ideal gas at standard conditions, ft ³ /lb-mole
T_m	=	meter temperature, °R
T_{ref}	=	reference temperature, °R
T_s	=	stack temperature, °R
V_s	=	stack gas velocity, ft/sec
V_{lc}	=	volume of liquid collected in impingers, ml
V_m	=	uncorrected dry meter volume, dcf
V_{mstd}	=	dry meter volume at standard conditions, dscf
V_{wstd}	=	volume of water vapor at standard conditions, scf
Y_d	=	meter calibration coefficient

APPENDIX C QUALITY ASSURANCE

Appendix C.1

Quality Assurance Program Summary

QUALITY ASSURANCE PROGRAM SUMMARY

As part of Montrose Air Quality Services, LLC (Montrose) ASTM D7036-04 certification, Montrose is committed to providing emission related data which is complete, precise, accurate, representative, and comparable. Montrose quality assurance program and procedures are designed to ensure that the data meet or exceed the requirements of each test method for each of these items. The quality assurance program consists of the following items:

- Assignment of an Internal QA Officer
- Development and use of an internal QA Manual
- Personnel training
- Equipment maintenance and calibration
- Knowledge of current test methods
- Chain-of-custody
- QA reviews of test programs

Assignment of an Internal QA Officer: Montrose has assigned an internal QA Officer who is responsible for administering all aspects of the QA program.

Internal Quality Assurance Manual: Montrose has prepared a QA Manual according to the requirements of ASTM D7036-04 and guidelines issued by EPA. The manual documents and formalizes all of Montrose's QA efforts. The manual is revised upon periodic review and as Montrose adds capabilities. The QA manual provides details on the items provided in this summary.

Personnel Testing and Training: Personnel testing and training is essential to the production of high quality test results. Montrose training programs include:

- A requirement for all technical personnel to read and understand the test methods performed
- A requirement for all technical personnel to read and understand the Montrose QA manual
- In-house testing and training
- Quality Assurance meetings
- Third party testing where available
- Maintenance of training records.

Equipment Maintenance and Calibration: All laboratory and field equipment used as a part of Montrose's emission measurement programs is maintained according to manufacturer's recommendations. A summary of the major equipment maintenance schedules is summarized in Table 1. In addition to routine maintenance, calibrations are performed on all sampling equipment according to the procedures outlined in the applicable test method. The calibration intervals and techniques for major equipment components is summarized in Table 2. The calibration technique may vary to meet regulatory agency requirements.

Knowledge of Current Test Methods: Montrose maintains current copies of EPA, ARB, and SCAQMD Source Test Manuals and Rules and Regulations.

Chain-of-Custody: Montrose maintains chain-of-custody documentation on all data sheets and samples. Samples are stored in a locked area accessible only to Montrose source test personnel. Data sheets are kept in the custody of the originator, program manager, or in locked storage until return to Montrose office. Electronic field data is duplicated for backup on secure storage media. The original data sheets are used for report preparation and any additions are initialed and dated.

QA Reviews: Periodic field, laboratory, and report reviews are performed by the in-house QA coordinator. Periodically, test plans are reviewed to ensure proper test methods are selected and reports are reviewed to ensure that the methods were followed and any deviations from the methods are justified and documented.

ASTM D7036-04 Required Information

Uncertainty Statement

Montrose is qualified to conduct this test program and has established a quality management system that led to accreditation with ASTM Standard D7036-04 (Standard Practice for Competence of Air Emission Testing Bodies). Montrose participates in annual functional assessments for conformance with D7036-04 which are conducted by the American Association for Laboratory Accreditation (A2LA). All testing performed by Montrose is supervised on site by at least one Qualified Individual (QI) as defined in D7036-04 Section 8.3.2. Data quality objectives for estimating measurement uncertainty within the documented limits in the test methods are met by using approved test protocols for each project as defined in D7036-04 Sections 7.2.1 and 12.10. Additional quality assurance information is presented in the report appendices.

Performance Data

Performance data are available for review.

Qualified Personnel

A qualified individual (QI), defined by performance on a third party or internal test on the test methods, is present on each test event.

Plant Entry and Safety Requirements

Plant Entry

All test personnel are required to check in with the guard at the entrance gate or other designated area. Specific details are provided by the facility and project manager.

Safety Requirements

All personnel shall have the following personal protective equipment (PPE) and wear them where designated:

- Hard Hat
- Safety Glasses
- Steel Toe Boots
- Hearing Protection
- Gloves
- High Temperature Gloves (if required)
- Flame Resistant Clothing (if required)

The following safety measures are followed:

- Good housekeeping
- SDS for all on-site hazardous materials
- Confine selves to necessary areas (stack platform, mobile laboratory, CEMS data acquisition system, control room, administrative areas)
- Knowledge of evacuation procedures

Each facility will provide plant specific safety training.

**TABLE 1
 EQUIPMENT MAINTENANCE SCHEDULE**

Equipment	Acceptance Limits	Frequency of Service	Methods of Service
Pumps	<ol style="list-style-type: none"> 1. Absence of leaks 2. Ability to draw manufacturers required vacuum and flow 	As recommended by manufacturer	<ol style="list-style-type: none"> 1. Visual inspection 2. Clean 3. Replace parts 4. Leak check
Flow Meters	<ol style="list-style-type: none"> 1. Free mechanical movement 	As recommended by manufacturer	<ol style="list-style-type: none"> 1. Visual inspection 2. Clean 3. Calibrate
Sampling Instruments	<ol style="list-style-type: none"> 1. Absence of malfunction 2. Proper response to zero span gas 	As recommended by manufacturer	As recommended by manufacturer
Integrated Sampling Tanks	<ol style="list-style-type: none"> 1. Absence of leaks 	Depends on nature of use	<ol style="list-style-type: none"> 1. Steam clean 2. Leak check
Mobile Van Sampling System	<ol style="list-style-type: none"> 1. Absence of leaks 	Depends on nature of use	<ol style="list-style-type: none"> 1. Change filters 2. Change gas dryer 3. Leak check 4. Check for system contamination
Sampling Lines	<ol style="list-style-type: none"> 1. Sample degradation less than 2% 	After each test series	<ol style="list-style-type: none"> 1. Blow dry, inert gas through line until dry

TABLE 2
MAJOR SAMPLING EQUIPMENT CALIBRATION REQUIREMENTS

Sampling Equipment	Calibration Frequency	Calibration Procedure	Acceptable Calibration Criteria
Continuous Analyzers	Before and After Each Test Day	3-point calibration error test	< 2% of analyzer range
Continuous Analyzers	Before and After Each Test Run	2-point sample system bias check	< 5% of analyzer range
Continuous Analyzers	After Each Test Run	2-point analyzer drift determination	< 3% of analyzer range
CEMS System	Beginning of Each Day	leak check	< 1 in. Hg decrease in 5 min. at > 20 in. Hg
Continuous Analyzers	Semi-Annually	3-point linearity	< 1% of analyzer range
NO _x Analyzer	Daily	NO ₂ -> NO converter efficiency	> 90%
Differential Pressure Gauges (except for manometers)	Semi-Annually	Correction factor based on 5-point comparison to standard	± 5%
Differential Pressure Gauges (except for manometers)	Bi-Monthly	3-point comparison to standard, no correction factor	± 5%
Barometer	Semi-Annually	Adjusted to mercury-in-glass or National Weather Service Station	± 0.1 inches Hg
Dry Gas Meter	Semi-Annually	Calibration check at 4 flow rates using a NIST traceable standard	± 2%
Dry Gas Meter	Bi-Monthly	Calibration check at 2 flow rates using a NIST traceable standard	± 2% of semi-annual factor
Dry Gas Meter Orifice	Annually	4-point calibration for ΔH@	--
Temperature Sensors	Semi-Annually	3-point calibration vs. NIST traceable standard	± 1.5%

Note: Calibration requirements that meet applicable regulatory agency requirements are used.

Appendix C.2

SCAQMD and STAC Certifications

SCS Engineers – Chiquita Canyon Landfill
2026 1st Quarter Leachate and Condensate Vapor Sampling



South Coast
Air Quality Management District

21865 Copley Drive, Diamond Bar, CA 91765-4178
(909) 396-2000 • www.aqmd.gov

September 18, 2025

Mr. John Peterson
Montrose Air Quality Services, LLC
1631 E. Saint Andrew Place
Santa Ana, CA 92705

Subject: LAP Approval Notice
Reference # 96LA1220

Dear Mr. Peterson:

We have completed our review of Montrose Air Quality Services' renewal application under the South Coast AQMD Laboratory Approval Program (LAP). We are pleased to inform you that your firm is approved for the period beginning September 30, 2025, and ending September 30, 2026, for the following methods, subject to the requirements in the LAP Conditions For Approval Agreement and conditions listed in the attachment to this letter:

South Coast AQMD Methods 1-4
South Coast AQMD Methods 10.1 and 100.1
South Coast AQMD Methods 5.1, 5.2, 5.3, 6.1 (Sampling and Analysis)
South Coast AQMD Methods 25.1 and 25.3 (Sampling)
Rule 1121/ 1146.2 Protocol
Rule 1420/1420.1/1420.2 – (Lead) Source and Ambient Sampling
USEPA CTM-030 and ASTM D6522-00

Your LAP approval to perform nitrogen oxide emissions compliance testing for Rule 1121/ 1146.2 Protocols includes satellite facilities located at:

McKenna Boiler
1510 North Spring Street
Los Angeles, CA 90012

Noritz America Corp.
11160 Grace Avenue
Fountain Valley, CA 92708

Ajax Boiler, Inc.
2701 S. Harbor Blvd.
Santa Ana, CA 92704

VA Laundry Bldg., Greater LA Healthcare Sys.
508 Constitution Avenue
Los Angeles, CA 90049

So Cal Gas – Engr Analysis Ctr, Bldg H
8101 Rosemead Blvd
Pico Rivera, CA 90660

Thank you for participating in the LAP. Your cooperation helps us to achieve the goal of the LAP: to maintain high standards of quality in the sampling and analysis of source emissions. You may direct any questions or information to me by telephone at (909) 396-2476, or via e-mail at ceckerle@aqmd.gov.

Sincerely,

Colin Eckerle
Program Supervisor
Source Test Engineering

CE/ce
Attachment
250918 LapRenewal.doc



American Association for Laboratory Accreditation

Accredited Air Emission Testing Body

A2LA has accredited

MONTROSE AIR QUALITY SERVICES

In recognition of the successful completion of the joint A2LA and Source Evaluation Society (SES) evaluation process, this laboratory is accredited to perform testing activities in compliance with ASTM D7036:2004 - Standard Practice for Competence of Air Emission Testing Bodies.



Presented this 23rd day of January 2026.

Mr. Trace McInturf, Vice President, Accreditation Services
For the Accreditation Council
Certificate Number 3925.01
Valid to February 29, 2028

This accreditation program is not included under the A2LA ILAC Mutual Recognition Arrangement.

Appendix C.3 Individual QI Certifications

CERTIFICATE OF COMPLETION

Pedro SanJuan

This document certifies that this individual has passed a comprehensive examination and is now a Qualified Individual (QI) as defined in Section 8.3 of ASTM D7036-04 for the following method(s):

SCAQMD Methods 1.1, 1.2, 2.1, 2.2, 2.3, 3.1, & 4.1

Certificate Number: 002-2022-50

Tate Strickler
Tate Strickler, VP – Quality Systems

DATE OF ISSUE: 02/28/2022

DATE OF EXPIRATION: 02/27/2027

MONTROSE
ENVIRONMENTAL

CERTIFICATE OF COMPLETION

Pedro SanJuan

This document certifies that this individual has passed a comprehensive examination and is now a Qualified Individual (QI) as defined in Section 8.3 of ASTM D7036-04 for the following method(s):

SCAQMD Methods 25.1, 25.3 & 307-91

Certificate Number: 002-2022-52

Tate Strickler
Tate Strickler, VP – Quality Systems

DATE OF ISSUE: 02/28/2022

DATE OF EXPIRATION: 02/27/2027

**MONTROSE**
ENVIRONMENTAL

CERTIFICATE OF COMPLETION

Pedro SanJuan

This document certifies that this individual has passed a comprehensive examination and is now a Qualified Individual (QI) as defined in Section 8.3 of ASTM D7036-04 for the following method(s):

EPA Methods 3C, TO-8, TO-12 and TO-15

Certificate Number: 002-2023-48

Tate Strickler
Tate Strickler, VP – Quality Systems

DATE OF ISSUE: 11/01/2023

DATE OF EXPIRATION: 10/31/2028

**MONTROSE**
ENVIRONMENTAL

Appendix C.4

Statement of No Conflict of Interest

**STATEMENT OF NO CONFLICT OF INTEREST AS AN INDEPENDENT TESTING
LABORATORY**

(To be completed by authorized source testing firm representative and included in source test report)

The following facility and equipment were tested by my source testing firm and are the subjects of this statement:

Facility ID:	119219
Date(s) Tested:	March 30, 2026
Facility Name:	Chiquita Canyon Landfill
Equipment Address:	29201 Henry Mayo Drive Castaic, California 91384
Equipment Tested:	Leachate and Condensate Sampling System

I state, as its legally authorized representative, that the source testing firm of:

Source Test Firm: Montrose Air Quality Services, LLC
Business Address: 1631 E. St. Andrew Pl.
Santa Ana, California 92705

is an "Independent Testing Laboratory" as defined in **District Rule 304(k)**:

For the purposes of this Rule, when an independent testing laboratory is used for the purposes of establishing compliance with District rules or to obtain a District permit to operate, it must meet all of the following criteria:

- (1) The testing laboratory shall have no financial interest in the company or facility being tested, or in the parent company, or any subsidiary thereof -*
- (2) The company or facility being tested, or parent company or any subsidiary thereof, shall have no financial interest in the testing laboratory;*
- (3) Any company or facility responsible for the emission of significant quantities of pollutants to the atmosphere, or parent company or any subsidiary thereof shall have no financial interest in the testing laboratory; and*
- (4) The testing laboratory shall not be in partnership with, own or be owned by, in part or in full, the contractor who has provided or installed equipment (basic or control), or monitoring systems, or is providing maintenance for installed equipment or monitoring systems, for the company being tested.*

Furthermore, I state that any contracts or agreements entered into by my source testing firm and the facility referenced above, or its designated contractor(s), either verbal or written, are not contingent upon the outcome of the source testing, or the source testing information provided to the SCAQMD.

Signature: _____

Date: 4/28/2026

Pete SanJuan

Client Project Manager

(714) 279-6777

4/28/2026

(Name)

(Title)

(Phone)

(Date)

APPENDIX D FACILITY PERMIT



**FACILITY PERMIT TO OPERATE
CHIQUITA CANYON LLC**

PERMIT TO CONSTRUCT/OPERATE

**Permit No. G66132
A/N 613131**

Equipment Description:

Modification of an existing Landfill Gas Condensate and Leachate Collection/Storage System consisting of:

1. Condensate storage tank, 5,000-gallon capacity, at Canyon B.
2. Condensate storage tank, 10,000-gallon capacity, at Primary Canyon.
3. Condensate storage tanks, three (3), each 6,650-gallon capacity, at flare station.
4. Leachate collection tanks, up to (4), each 10,000-gallon capacity, and one 1,600-gallon capacity, with associated sump pump and transfer pumps.

By removal of:

1. One 1,600-gallon capacity leachate collection tank [under Item 4].

By addition of:

1. One 10,000-gallon capacity leachate collection tank [to Item 4].

Conditions:

1. Operation of this equipment shall be conducted in accordance with all data and specifications submitted with the application under which this permit is issued unless otherwise noted below.
[Rule 204]
2. This equipment shall be properly maintained and kept in good operating condition at all times.
[Rule 204]
3. This equipment shall be operated and maintained by personnel properly trained in its operation.
[Rule 204]
4. This equipment shall be vented to air pollution control equipment which is in full operation and has been issued a valid Permit to Construct or Operate by the South Coast AQMD.
[Rule 1303(a)(1)-BACT]
5. This equipment shall be used only for the storage of landfill gas condensate and leachate collection.
[Rule 204]
6. All connectors, valves and openings shall be properly sealed or closed at all times to prevent landfill gas condensate vapors from entering into the atmosphere unless disposal of the condensate/leachate is taking place or during maintenance or repairs.
[Rule 204]



**FACILITY PERMIT TO OPERATE
CHIQUITA CANYON LLC**

7. Any breakdown or malfunction of the landfill gas condensate/leachate storage system shall be reported to South Coast AQMD within one hour after occurrence, or within one hour of the time personnel knew or reasonably should have known of its occurrence, per Rule 430 requirements, and remedial measures shall be undertaken to correct the problem and prevent further emissions into the atmosphere in a timely manner.
[Rule 430]
8. The operator shall keep and maintain adequate records for this equipment to verify compliance with the conditions of this permit. These records shall be prepared in a format which is acceptable to the South Coast AQMD. Records shall be kept for at least five years and made available to South Coast AQMD personnel upon request.
[Rule 204]
9. This permit shall expire if construction of this equipment is not complete within one year from the date of issuance of this permit unless an extension is granted by the Executive Officer.
[Rule 204]

THIS IS THE LAST PAGE OF THIS DOCUMENT

If you have any questions, please contact one of the following individuals by email or phone.

Name: Mr. Pete SanJuan
Title: Client Project Manager
Region: West
Email: PSanjuan@onterris.com
Phone: (714) 279-6777

Name: Mr. Matt McCune
Title: Principal
Region: West
Email: MMccune@onterris.com
Phone: (714) 279-6777