

COMPONENTS | Hardware

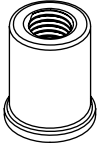

Ceiling Locator
x2



Cable Gripper
x2

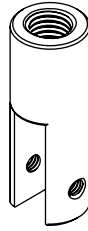

Bracket Housing
x2

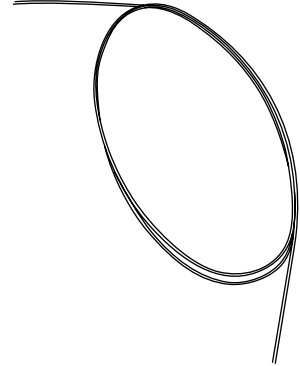

Stainless Steel Cable (5 ft)
x2

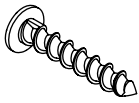

Self Tapping Screw
x2



Inset Screw M6x8
x2



Inset Screw M5x16
x2

COMPONENTS | Felt Screen

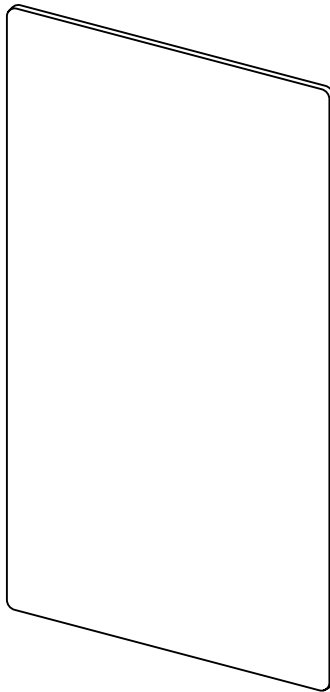

PHASE 1 | Suspension

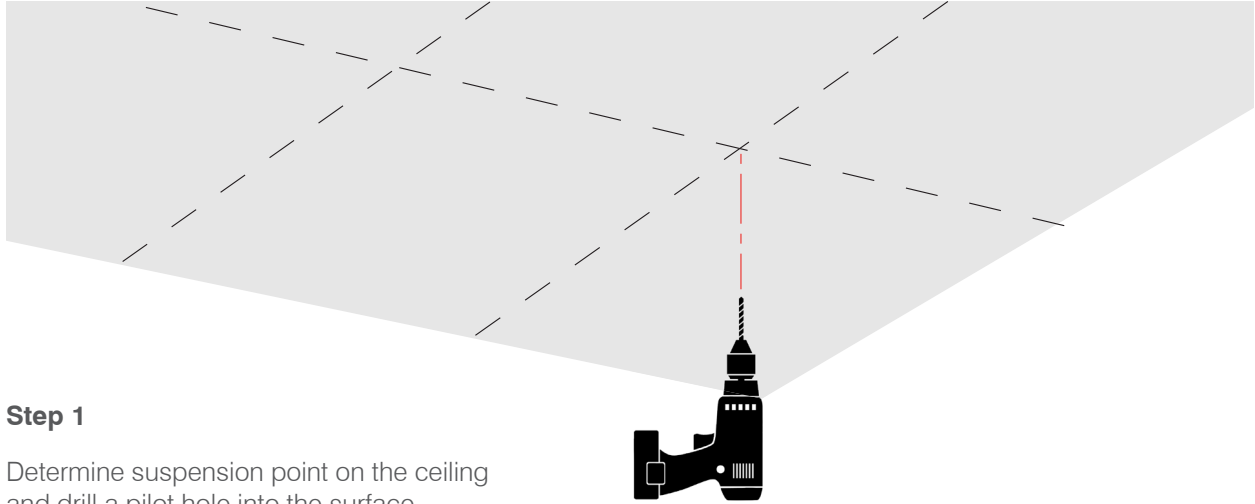

Step 1

Determine suspension point on the ceiling and drill a pilot hole into the surface.

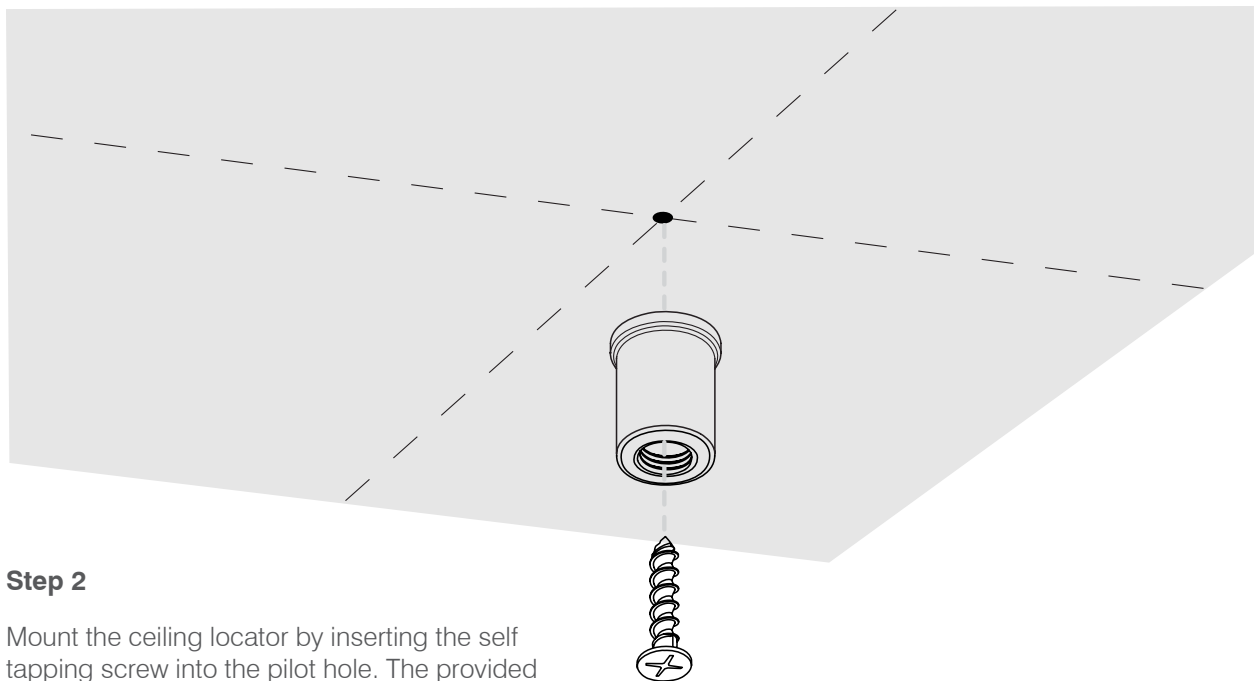

Step 2

Mount the ceiling locator by inserting the self tapping screw into the pilot hole. The provided screw is intended for wooden and plaster material. Users should determine the correct hardware needed for their applicable ceiling material.

PHASE 1 | Suspension

Step 3

Insert the cable into the cable gripper and secure using an M6x8 screw. Thread cable gripper into the ceiling locator and tighten by hand only.

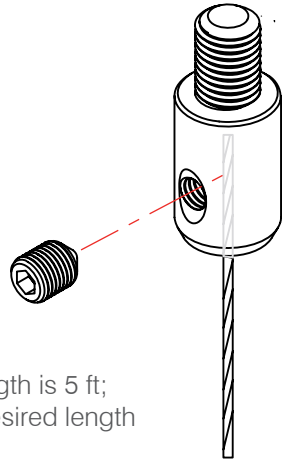

NOTE: The provided cable length is 5 ft; however, users may trim to desired length based on the ceiling height.

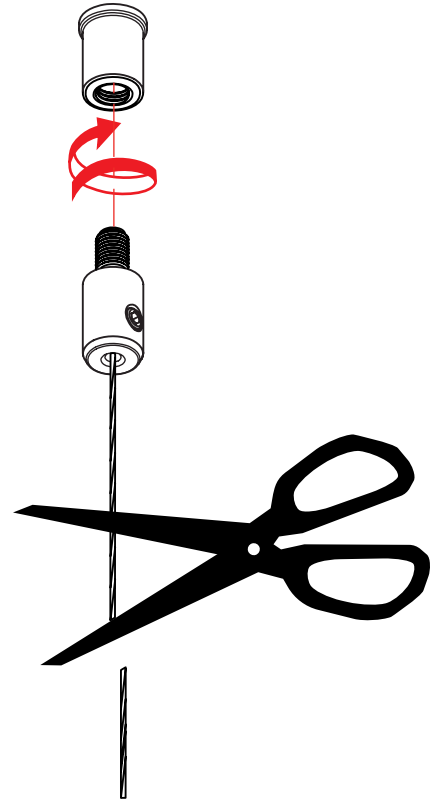

Step 4

Insert the other end of the cable into the cable gripper and secure using an M6x8 screw. Thread cable gripper into the bracket housing and tighten by hand only.

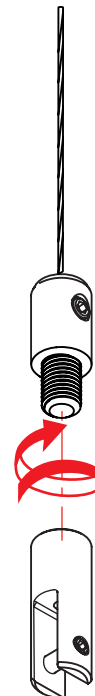
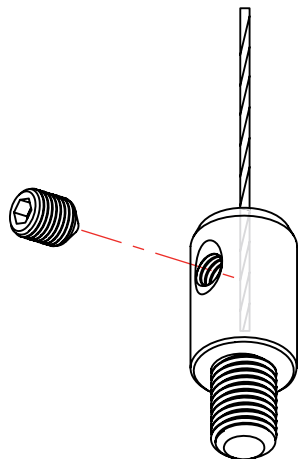

PHASE 1 | Suspension

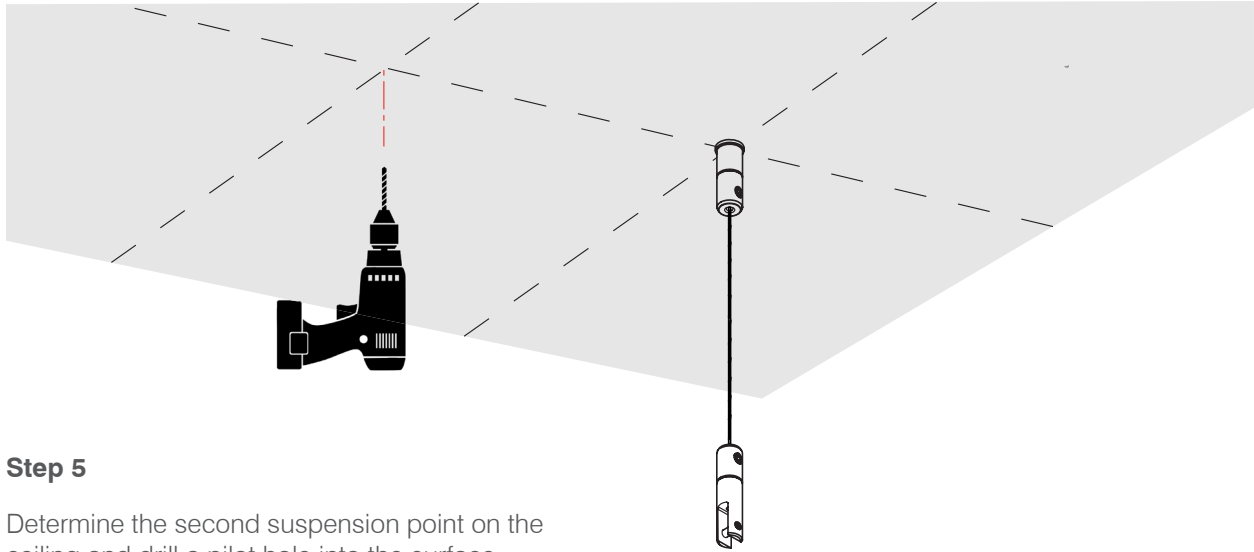

Step 5

Determine the second suspension point on the ceiling and drill a pilot hole into the surface.

Repeat steps 2-4.

Recommended spacing between ceiling locators:

28" panel: 20" apart

38" panel: 26" apart

48" panel: 36" apart

PHASE 2 | Panel attachment

Step 1

Locate and drill pilot holes for the bracket housing on the panel.

Use bracket housing along the top of the panel to mark pilot holes.

Recommended spacing:

28" panel: 4" apart

38" panel: 6" apart

48" panel: 6" apart

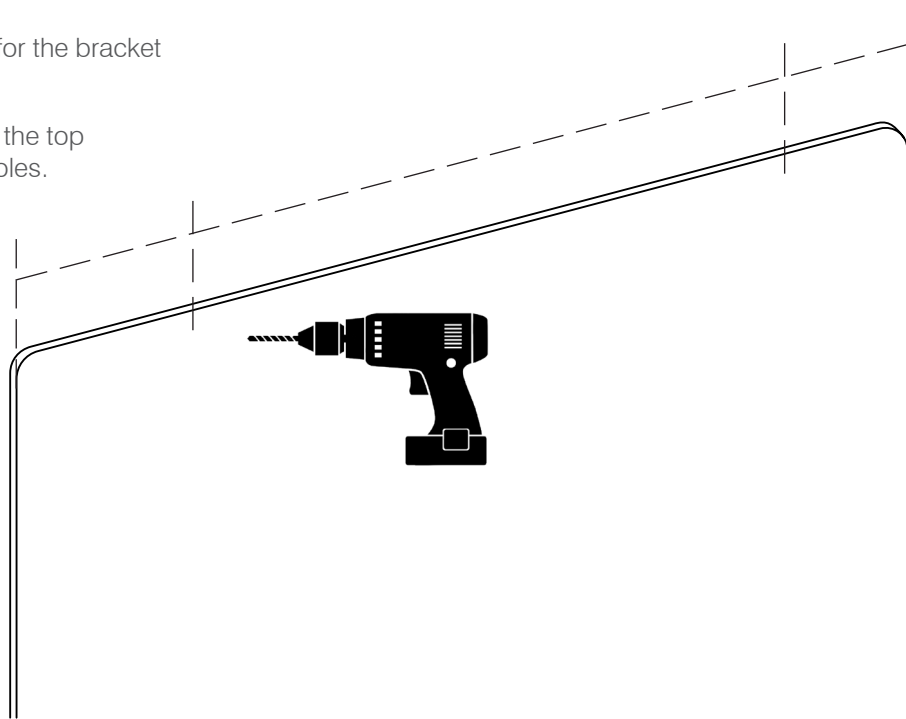

Step 2

Align the bracket housing with the pilot hole in the panel and secure using an M5x16 screw.

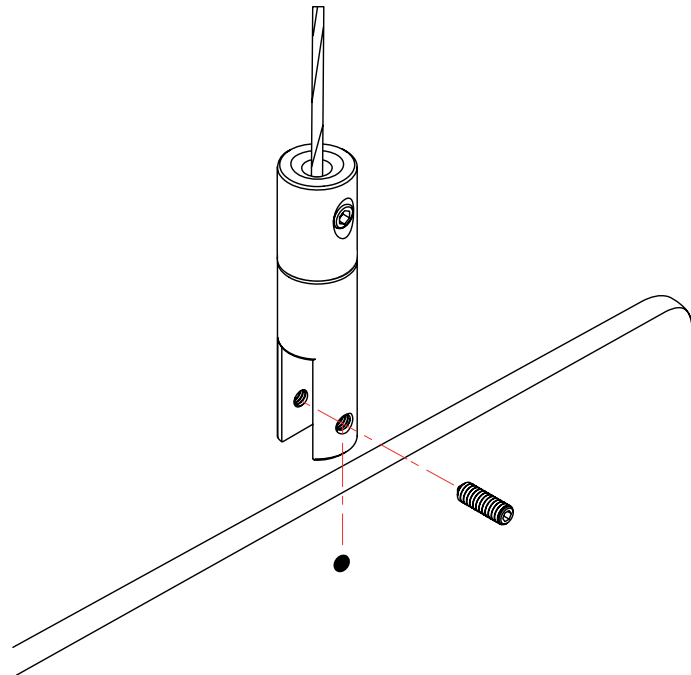

PHASE 2 | Panel attachment

Step 3

Tighten the screw to ensure panel is held in place.

Tighten the screw to ensure the screw goes all the way through the panel and stays flush

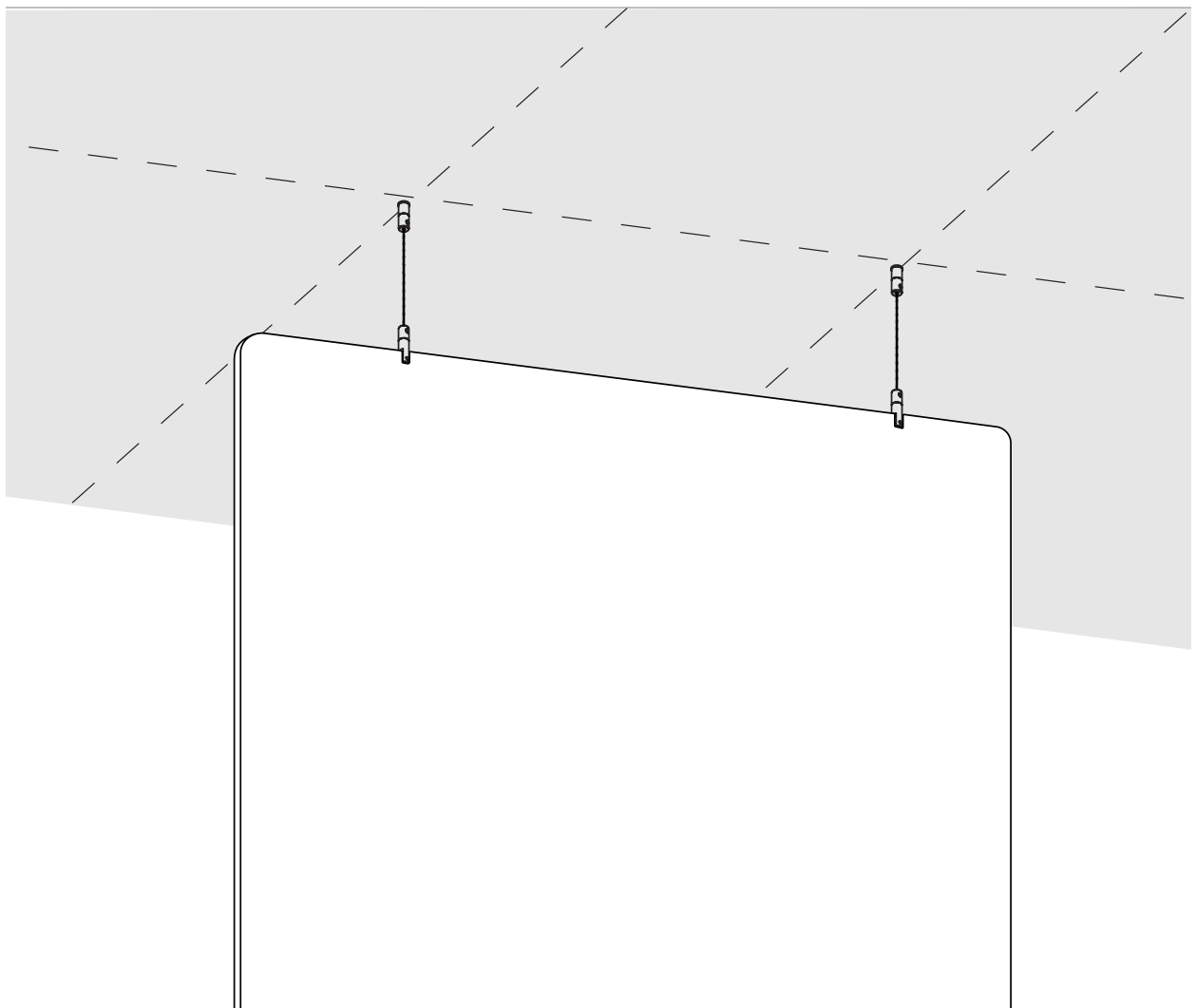
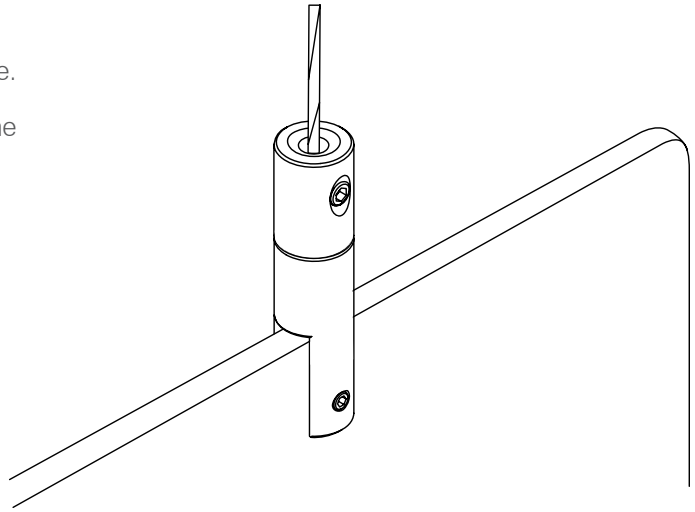

Please contact cc@amqsolutions.com if you are missing any parts, have difficulty with assembly, or have any product related questions.